



www.khartindustries.com

8612 Opener

Owner's Manual

Box 520
Elrose, Saskatchewan S0L 0Z0
Canada
Ph: (306)378-2258
Fax: (306)378-2926
E-mail: sales@khartindustries.com

Rev. 0
02-Dec-2019

This page intentionally left blank

Contents

Safety	4
Warranty	7
Specifications	8
Operation	9
Maintenance	13
Assembly and Parts	14
General	14
8612 Opener—Major Sub-Assemblies and Weldments	16
679550: 8612 Opener Assembly, Right	18
679555: 8612 Opener Assembly, Left	20
679650: 8612 Opener Assembly, Right—RST	22
679655: 8612 Opener Assembly, Left—RST	24
278310: Spring Assembly	26
278280: Spring Base Assembly	28
678250: Gent Opener Assembly, Right	30
678255: Gent Opener Assembly, Left	32
678260: Gent Opener Assembly, Right—RST	34
678265: Gent Opener Assembly, Left—RST	36
678400: Paralink Linkage Assembly	38
268020: 17" Disc Assembly	40
268025: 14.8" Disc Assembly	42
Wheels	44
Notes	46

Safety

SAFETY-ALERT SYMBOL



Watch for this symbol. It identifies potential hazards to health or personal safety. It means:

ATTENTION—BE ALERT Your Safety is Involved

Familiarize yourself with the location of all decals. Read them carefully to understand the safe operation of your machine.

Three words are used in conjunction with the safety-alert symbol:



DANGER

Indicates an imminently hazardous situation that, if not avoided, will result in death or serious injury.



WARNING

Indicates a potentially hazardous situation that, if not avoided, could result in serious injury or death.



CAUTION

Indicates a potentially hazardous situation that, if not avoided, may result in minor or moderate injury.



Tractor Operation

- Be aware of tractor safety procedure when working with an air drill.
- Review tractor manuals.
- Secure hitch pin with a retainer and lock drawbar in centre position.



General Operation

- **DO NOT RIDE!!** No one should be allowed to ride on the air drill when in motion.
- No one but the operator in the driver's compartment.
- Check behind when backing up.
- Reduce speed when working in hilly terrain.
- Never allow anyone within the immediate area when working.
- Stand clear when raising or lowering wings.



Transporting Operation

- When transporting be aware of length, height, and width. Make turns carefully and be aware of obstacles and overhead electrical lines.
- When transporting machine adhere to recommended safe speed. DO NOT EXCEED 20 MPH.
- Do not transport in poor visibility.
- When transporting, be sure transport lock pins are in locking position.
- The slow moving vehicle (SMV) emblem and safety reflectors must be secured on the machine for safe transport
- Check that wings are firmly seated in transport wing stops and lock pins installed.
- Avoid soft surfaces. The additional wing weight on the centre wheels could cause the machine to sink.
- Ensure safety chain is attached correctly.



Maintenance

- Shut the tractor off before making any adjustments or lubricating the machine.
- Block machine securely when making repairs.
- Wear close-fitted clothing.
- Do not modify the machine.



Hydraulics

- Do not search for high pressure hydraulic leaks without hand and face protection. A tiny, almost invisible leak can penetrate the skin, requiring immediate medical attention.
- Use cardboard or wood to detect leaks, never your hands!
- Double check that all is clear before operating hydraulics.
- Never remove hoses or hose ends with machine elevated. Ensure all pressure is off of lines to be disassembled.
- Maintain proper hydraulic fluid levels.
- Keep all connectors clean for positive connections.
- Ensure all fittings and hoses are in good repair.
- Do not stand under wings.



Storage

- Store air drill away from areas of main activity.
- Level air drill and block up securely to relieve pressure on jack.
- Do not allow children to play on or around air drill.

Safety

Familiarize yourself with the location of all decals. Read them carefully to understand the safe operation of your machine. If any decals become damaged or missing, contact your dealer immediately for a replacement.



CAUTION

- READ AND UNDERSTAND THE OPERATORS MANUAL BEFORE OPERATING.
- FOR ROAD TRAVEL, USE FLASHING LIGHTS AND AN SMV SIGN AS REQUIRED. OBSERVE HIGHWAY TRAFFIC REGULATIONS.
- NO RIDERS.

N24301

TAKE SAFETY SERIOUSLY.

**DON'T TAKE
NEEDLESS CHANCES!!**



CAUTION

**DO NOT SERVICE
HYDRAULIC SYSTEM
WHILE UNDER PRESSURE.**

C-1262



CAUTION

**TRANSPORT WHEELS MUST BE
LOCKED IN PLACE BEFORE
FOLDING UNIT UP OR DOWN
AND WHEN TRANSPORTING.
FAILURE TO DO SO COULD
RESULT IN SEVERE DAMAGE**

822441



CAUTION

**TRANSPORT LOCK
... MUST BE INSTALLED BEFORE
TRANSPORTING MACHINE. SEE
OPERATORS MANUAL.**

F-4644



DANGER

- WINGS MAY FALL RAPIDLY CAUSING BODILY INJURY.
- ALWAYS STAY CLEAR OF FOLDING WINGS WHEN BEING RAISED, LOWERED, OR IN ELEVATED POSITION.
- ALWAYS INSTALL ALL LOCKUP DEVICES PROVIDED WHEN WINGS ARE IN ELEVATED POSITION.
- ENSURE CYLINDER IS COMPLETELY FILLED WITH HYDRAULIC FLUID TO AVOID UNEXPECTED MOVEMENT.



811794

Warranty

K-Hart's objective is to insure that all owners obtain maximum reliability and performance from all K-Hart products.

K-Hart Industries warrants your K-Hart products to be free of defects in material and workmanship, under normal use and service. Obligations under this warranty shall extend for a period of 1 year following the date of delivery to the original purchaser and shall be limited to, at the option of K-Hart Industries, replacement or repair of any parts found, upon inspection by K-Hart, to be defective.

K-Hart Industries reserves the right to make changes or add improvements at any time without notice or obligation.

Warranty claims

The purchaser claiming under this warranty shall report a warranty claim to his Authorized dealer.

Exclusions and/or Deviations from the Base Warranty

- K-Hart does not cover any warranty on the frame tires. Any warranty has to be dealt with by the Original Tire Manufacturer.
- K-Hart does not cover any nicks, cuts, or other marks on the frame tires that occur during delivery.
- Rubber packer wheels, when used in excessively rocky conditions and will not be warranted against cuts, scrapes, and abrasions.
- **Limitation of Liability.** In no event shall the owner be entitled to recover for incidental, special or consequential damages such as, but not limited to, loss of crops, loss of profits or revenue, other commercial losses, inconvenience or cost of rental or replacement.
- **Normal wear, repair and maintenance not related to defects.** The expressed warranty does not cover wear of components, and is conditional upon the product being properly assembled, adjusted, and operated under normal farming conditions.

This warranty does not cover conditions resulting from misuse, negligence, unauthorized alterations, accident, or lack of performance of required maintenance.

Owner's Obligation

Warranty Transportation Costs. It is the responsibility of the owner, at the owner's expense, to transport the equipment to the service shop of an authorized K-Hart dealer or alternately for any travel or transportation expense involved in fulfilling this warranty.

Specifications

10" Spacing

Width (ft)	Sections	Number of Openers	Approximate Weight base unit (lbs)*		
			Frame	Openers	Total
34	3	40	10300	7060	17360
42	3	52 (9.75" spacing)	10700	9180	19880
50	3	60	16250	10590	26840
56	5	66	20700	11300	32000
66	5	80	21300	13770	35070
76	5	90	21700	15530	37230

12" Spacing

Width (ft)	Sections	Number of Openers	Approximate Weight base unit (lbs)*		
			Frame	Openers	Total
34	3	34	10300	6000	16300
42	3	42	10700	7410	18110
50	3	50	16250	8830	25080
56	5	56	20700	9530	30230
66	5	66	21300	11470	32770
76	5	76	21700	13060	34760

*Weights are approximate and will vary depending on options selected.
 Additional weight can be added.
 All specifications are subject to change without notification.

Hitching

- Insure your hitch pin is in good condition.
- Position air drill clevis with tractor drawbar using hitch jack.
- After tractor to air drill connection is made, relieve pressure off the hitch jack.
- Pull jack pin. Swing hitch jack parallel to hitch pole and re-pin jack.
- Connect safety chain.

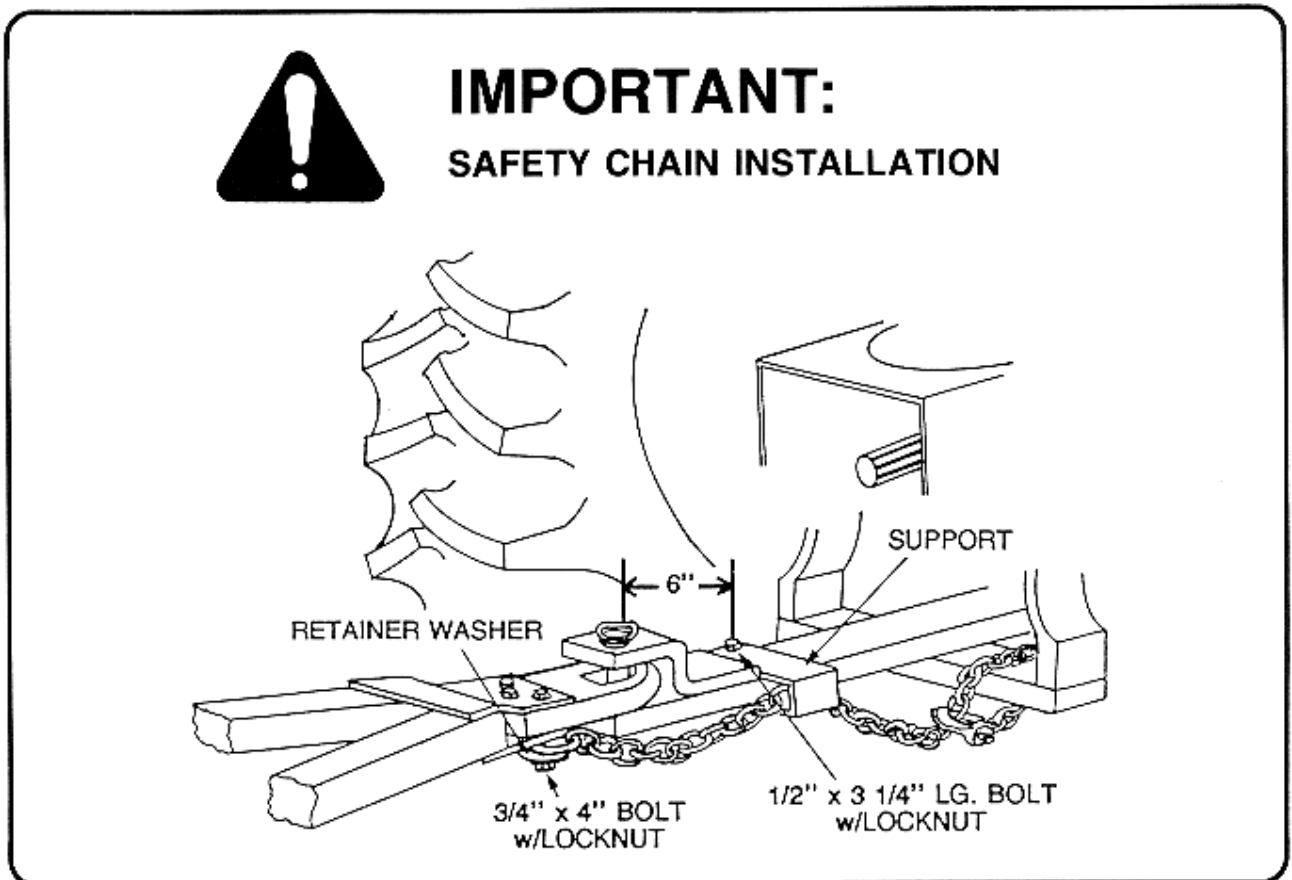

Hydraulics

- Ensure quick couplers are dirt free.
- **Dirt in the hydraulic system could damage o-rings, causing leakage, pressure loss, and total system failure!**
- Inspect all fittings and hoses for leaks, bends, or kinks.
- Connect the four hydraulic lines. Be sure the wing and depth hoses are matched and connected to the correct valve.

Operation

Operation



- Make sure that the wheel bolts on the main center frame and the wings are tightened after the first 5 km and then after the next 10 km and the next 20 km during the first few hours of use or transporting. After the initial use, check wheel bolts every 40 hours of operation.

Leveling

- Initial leveling should be done on a flat, level surface, similar to that of a concrete floor.



- Using selector valve, select leveling cylinder operation and level frame from front to back.
- With frame level, close lock valve.
- Switch selector valve back to wing fold/unfold operation.

- Level the wings using the 1 1/8" threaded rod that is located on the end of the frames attached to the wing wheel module.



- Ensure the unfold cylinders are fully extended so the rod end is 1/2 way in the slot. This allows full travel of wing members in uneven terrain. Not fully extending cylinders will cause stress on frame and cylinders and may do damage to your equipment.
- When in field mode always run tractor hydraulics for the wing cylinders in the float position.

Height Adjustment



- The height of the frame is controlled by a series of donuts located on the lift cylinders on the center frame. **IMPORTANT:** Simply add or remove the donuts to set the height, making sure both cylinders are set the same. This will prevent the rear rockshaft from twisting due to one cylinder traveling farther than the other.
- Unused donuts can be stored over 5/8" bolt.

Transporting

- **Use safety locks on main frame and wings when transporting!**
- Do not walk under wings when raised or lowered. Ensure cylinders are completely filled with hydraulic fluid. Entrapped air or hydraulic system failure could cause wings to fall rapidly causing serious injury or death.
- Never exceed 20 mph (32 kph) in transport.

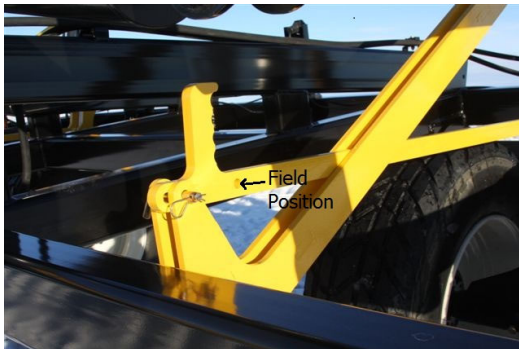

Transport Main Frame Lock



Transport Wing Lock

- Wing lock pins are to be removed from storage location and placed securely in position when transporting or working under or near the machine.
- Main frame locks are to be used also when transporting or working under or near machine.
- Lift machine to the full up position, remove the 3/8" bent handle pin, push transport safety arm under cylinder and reinstall 3/8" bent handle pin in position. Both LH & RH cylinder locks need to be in place. If only one safety lock is used, and there is hydraulic oil seepage, this may twist the main frame rockshaft.

Operation

Setting Openers

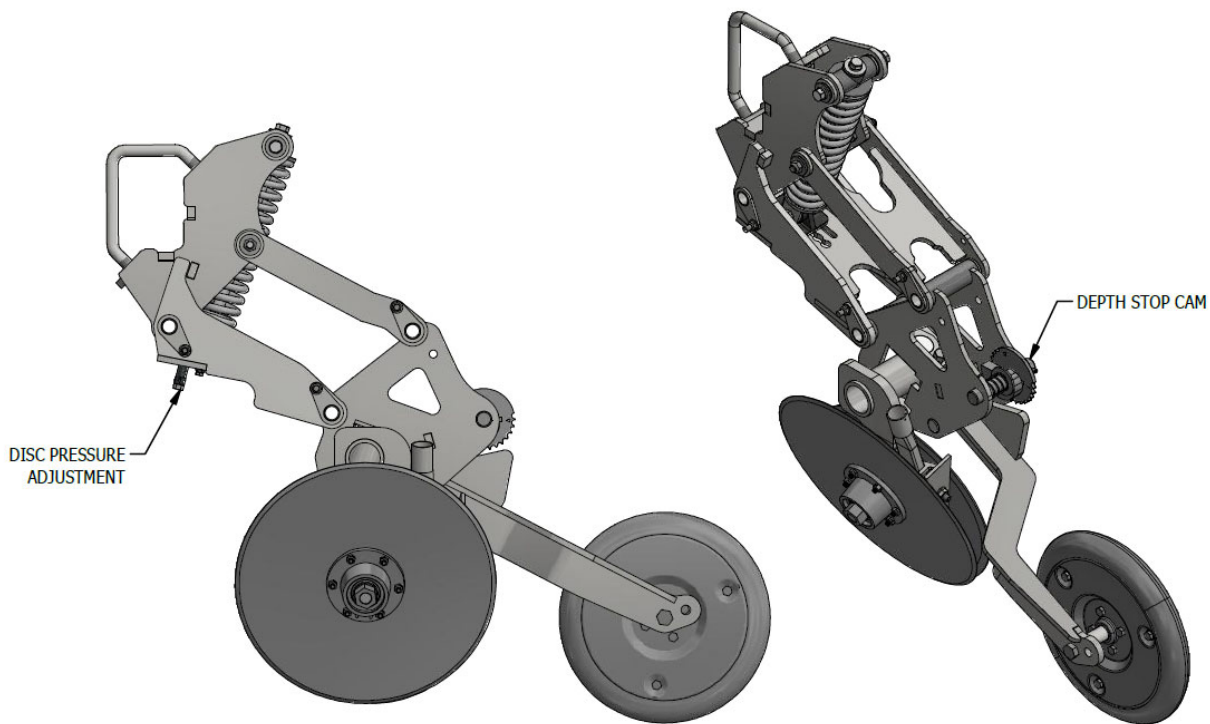

- By adjusting the main tension spring, you will increase the penetrating force of the opener. Moving the bottom of the disc pressure spring towards the rear increases down pressure. Moving the bottom of the disc pressure spring forward towards the tractor decreases down pressure.
- The depth stop cam limits the amount of travel the disk opener can penetrate the soil and can also affect packing pressure. Adjustments to the cam can be made by pushing in the shaft and moving to the next gear. This adjustment is in 1/4" increments.
- Travel speed will affect disc penetration and varies upon soil condition, type, and depth of seeding.
- Depth of seeding and packing pressure is related to what height you are operating the frame with the depth stop donuts.

Use safety lock pins when doing any maintenance on the machine!

Frame

Daily or every 10 hours

- Grease rear rockshaft.

Weekly or every 50 hours

- Check for and tighten loose wheel bolts.
- Check tire pressure. Tires should be maintained at a pressure of 105 psi.
- Inspect all hinge pins to ensure they are in place.
- Inspect hydraulic system for leaks, damaged hoses, and loose fittings.

Annually or every 200 hours

- Grease main wheel hubs.
- Check for any cracked or broken welds.
- Check for and tighten loose wheel bolts.
- Check tire pressure.
- Inspect all hinge pins to ensure they are in place.
- Inspect hydraulic system for leaks, damaged hoses, and loose fittings.



Openers

Annually or every 100 hours

- Grease opener hubs.
- Grease opener pivot arm pin.
- Ensure that all spindle bolts are tight.
- Check for any other loose hardware.
- Check inner blade clearance and remove shims if required. Discs should just touch. Use anti-seize on spindle when replacing so that it is easy to remove the next time.
- Adjust mud scraper clearance.
- Oil blades after the season if desired to keep them from rusting.
- Change blades if diameter is small enough that performance is compromised.
- When installing new blades, ensure that ample anti-seize is placed on disk hub spindle for easy removal next time hubs are removed.

General

- Assembly procedure is shown in the following pages. Assembly and parts are shown for all coultter systems and options. Your system may not have all the illustrated parts.
- Tighten all bolts to the torques shown in the following table unless otherwise instructed. All u-bolts should be torqued to the Grade 5 specification.
- Lubricate all bearings and moving parts as assembled.

Bolt Torque Chart				
Bolt Size	Grade 5 		Grade 8 	
	ft*lbs	N*m	ft*lbs	N*m
1/4	8	11	12	16
5/16	17	23	24	33
3/8	30	41	45	61
7/16	50	68	70	95
1/2	75	102	105	142
9/16	110	149	155	210
5/8	150	203	210	285
3/4	270	366	375	508
7/8	395	536	610	827
1	590	800	910	1234

This page intentionally left blank

Assembly and Parts

8612 Opener—Major Sub-Assemblies and Weldments

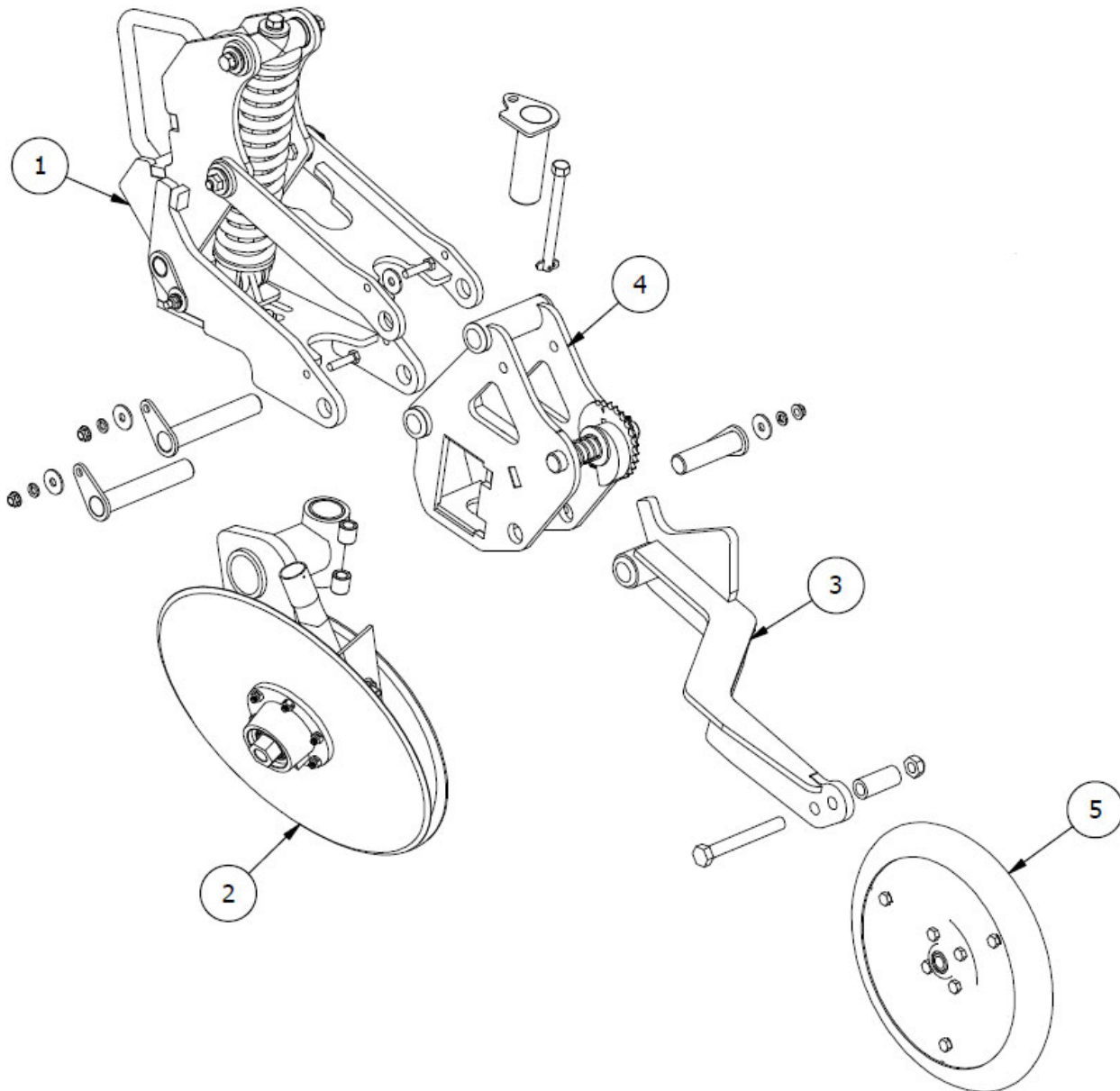

Assembly and Parts

8612 Opener—Major Sub-Assemblies and Weldments

Item	Part No	Rev	Description	Qty
1	678400	0	PARALINK LINKAGE ASSEMBLY	1
2	678250	2	GENT OPENER ASSEMBLY, RH	1
	678255	2	GENT OPENER ASSEMBLY, LH	1
	678260	2	GENT OPENER ASSEMBLY, RH—RST	1
	678265	2	GENT OPENER ASSEMBLY, LH—RST	1
3	677610	2	PACKER ARM WELDMENT, RH—RST	1
	667613	2	PACKER ARM WELDMENT, LH—RST	1
	677630	2	OFFSET PACKER ARM WELDMENT, RH	1
	677633	2	OFFSET PACKER ARM WELDMENT, LH	1
4	667280	2	MOUNT WELDMENT, RH	1
	677283	1	MOUNT WELDMENT, LH	1
5	WO214VT	1	PACKER WHEEL, 2 X 14 VT CMLPT	1

******DO NOT OVERTIGHTEN BOLTS******
Tighten to Grade 5 Torque Specifications Pg-15

Assembly and Parts

679550: 8612 Opener Assembly, Right

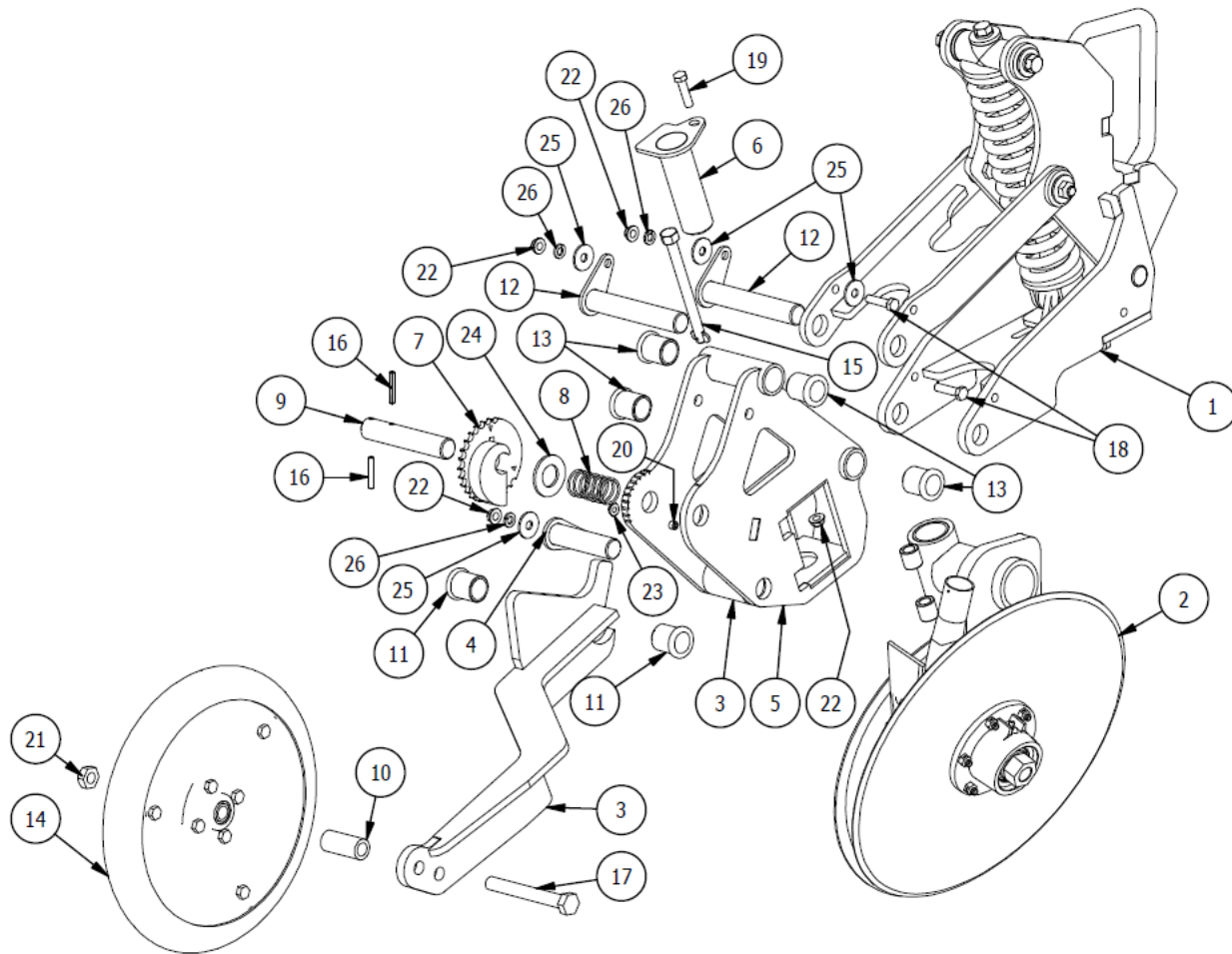

Assembly and Parts

679550: 8612 Opener Assembly, Right

Item	Part No	Rev	Description	Qty
1	678400	0	PARALINK LINKAGE ASSEMBLY	1
2	678250	0	GENT OPENER ASSEMBLY, RH	1
3	677630	0	OFFSET PACKER ARM WELDMENT, RH	1
4	677605	2	PACKER PIVOT PIN	1
5	677280	0	MOUNT WELDMENT, RH	1
6	677270	2	PIVOT PIN	1
7	497110	1	CAM, RIGHT	1
8	496010	4	SPRING	1
9	493142	2	CAM STOP SHAFT	1
10	493120	1	PACKER WHEEL SPACER	1
11	316001	0	BUSHING, 1 ID X 1-1/4 LG, BLACK	2
12	277265	2	PIVOT PIN	2
13	276222	2	BUSHING, 1ID X 1-1/4 LG, WHITE	4
14	WO214VT	1	PACKER WHEEL, 2 X 14 VT CMPLT	1
15	HPL0424	0	HITCH PIN W/ LOCK, 1/4 X 6	1
16	RP0406	0	ROLL PIN 1/4 X 1-1/2	2
17	SB1020C5P	0	BOLT, HEX, 5/8 UNC X 5 GR5 PL	1
18	SB0606CP	0	BOLT, 3/8 UNC X 1-1/2 PL W/ 1/2 THREAD	3
19	SB0604C5P	0	BOLT, HEX, 3/8 UNC X 1 GR5 PL	1
20	SCS0404C	0	BOLT, SOCKET HEAD, 1/4 UNC X 1	1
21	LS10CBP	0	LOCKNUT, STOVER 5/8 UNC GRB PL	1
22	LSF06CCP	0	LOCKNUT, STOVER, 3/8 UNC GRC	4
23	LSF04CFP	0	LOCKNUT, FLANGED, 1/4 UNC GRF	1
24	WF1632134P	0	WASHER, 1 SAE PL	1
25	WF0602019P	0	WASHER, HEAVY, 3/8 PL	4
26	WL06P	0	WASHER, LOCK 3/8 PL	3

******DO NOT OVERTIGHTEN BOLTS******
Tighten to Grade Torque Specifications Pg-15

Assembly and Parts

679555: 8612 Opener Assembly, Left

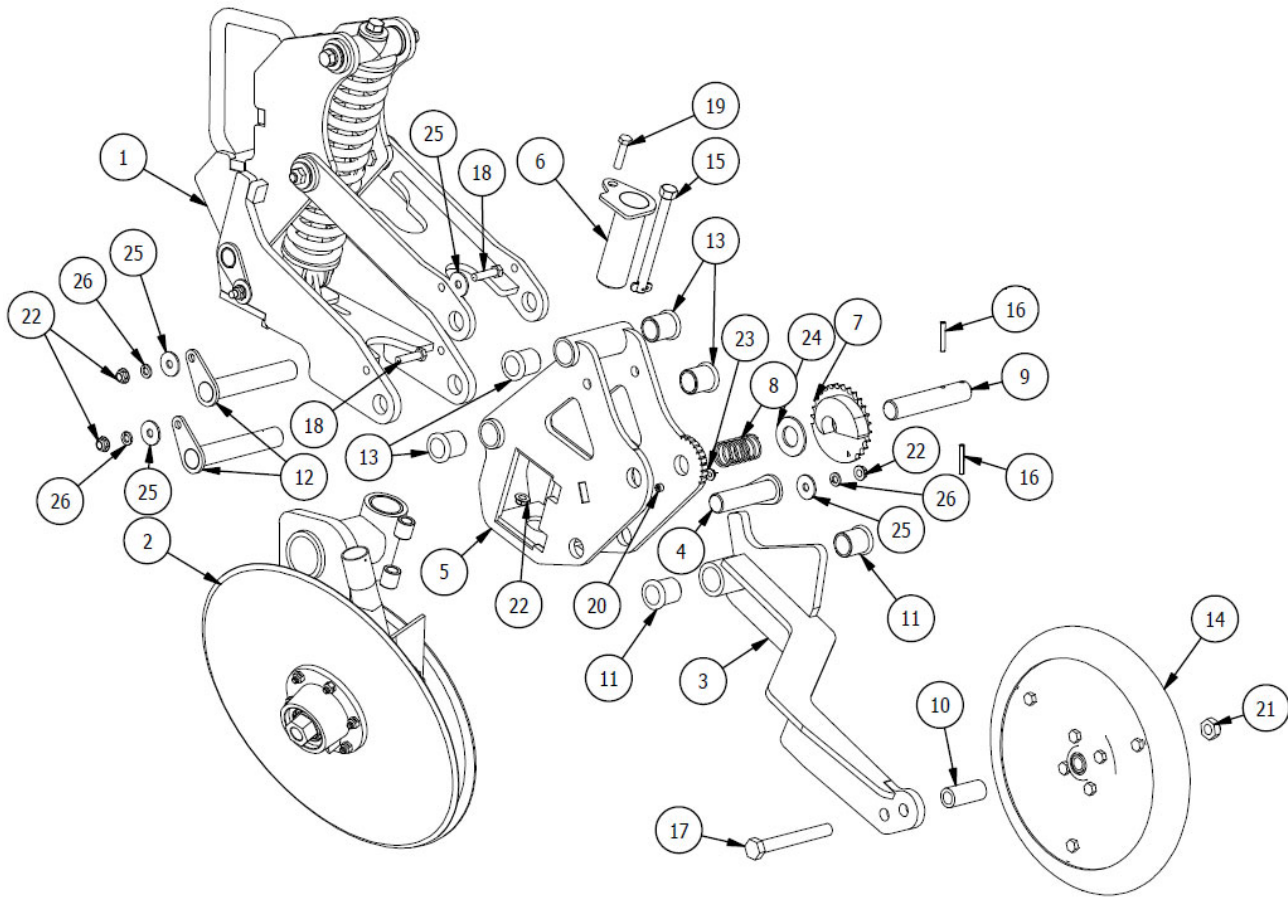

Assembly and Parts

679555: 8612 Opener Assembly, Left

Item	Part No	Rev	Description	Qty
1	678400	0	PARALINK LINKAGE ASSEMBLY	1
2	678255	2	GENT OPENER ASSEMBLY, LH	1
3	677633	0	OFFSET PACKER ARM WELDMENT, LH	1
4	677605	2	PACKER PIVOT PIN	1
5	677283	2	MOUNT WELDMENT, LH	1
6	677270	2	PIVOT PIN	1
7	497114	1	CAM, LEFT	1
8	496010	4	SPRING	1
9	493142	2	CAM STOP SHAFT	1
10	493120	1	PACKER WHEEL SPACER	1
11	316001	0	BUSHING, 1 ID X 1-1/4 LG, BLACK	2
12	277265	2	PIVOT PIN	2
13	276222	2	BUSHING, 1ID X 1-1/4 LG, WHITE	4
14	WO214VT	1	PACKER WHEEL, 2 X 14 VT CMLPT	1
15	HPL0424	0	HITCH PIN W/ LOCK, 1/4 X 6	1
16	RP0406	0	ROLL PIN 1/4 X 1-1/2	2
17	SB1020C5P	0	BOLT, HEX, 5/8 UNC X 5 GR5 PL	1
18	SB0606CP	0	BOLT, 3/8 UNC X 1-1/2 PL W/ 1/2 THREAD	3
19	SB0604C5P	0	BOLT, HEX, 3/8 UNC X 1 GR5 PL	1
20	SCS0404C	0	BOLT, SOCKET HEAD, 1/4 UNC X 1	1
21	LS10CBP	0	LOCKNUT, STOVER 5/8 UNC GRB PL	1
22	LSF06CCP	0	LOCKNUT, STOVER, 3/8 UNC GRC	4
23	LSF04CFP	0	LOCKNUT, FLANGED, 1/4 UNC GRF	1
24	WF1632134P	0	WASHER, 1 SAE PL	1
25	WF0602019P	0	WASHER, HEAVY, 3/8 PL	4
26	WL06P	0	WASHER, LOCK 3/8 PL	3

******DO NOT OVERTIGHTEN BOLTS******
Tighten to Grade Torque Specifications Pg-15

Assembly and Parts

679650: 8612 Opener Assembly, Right —RST

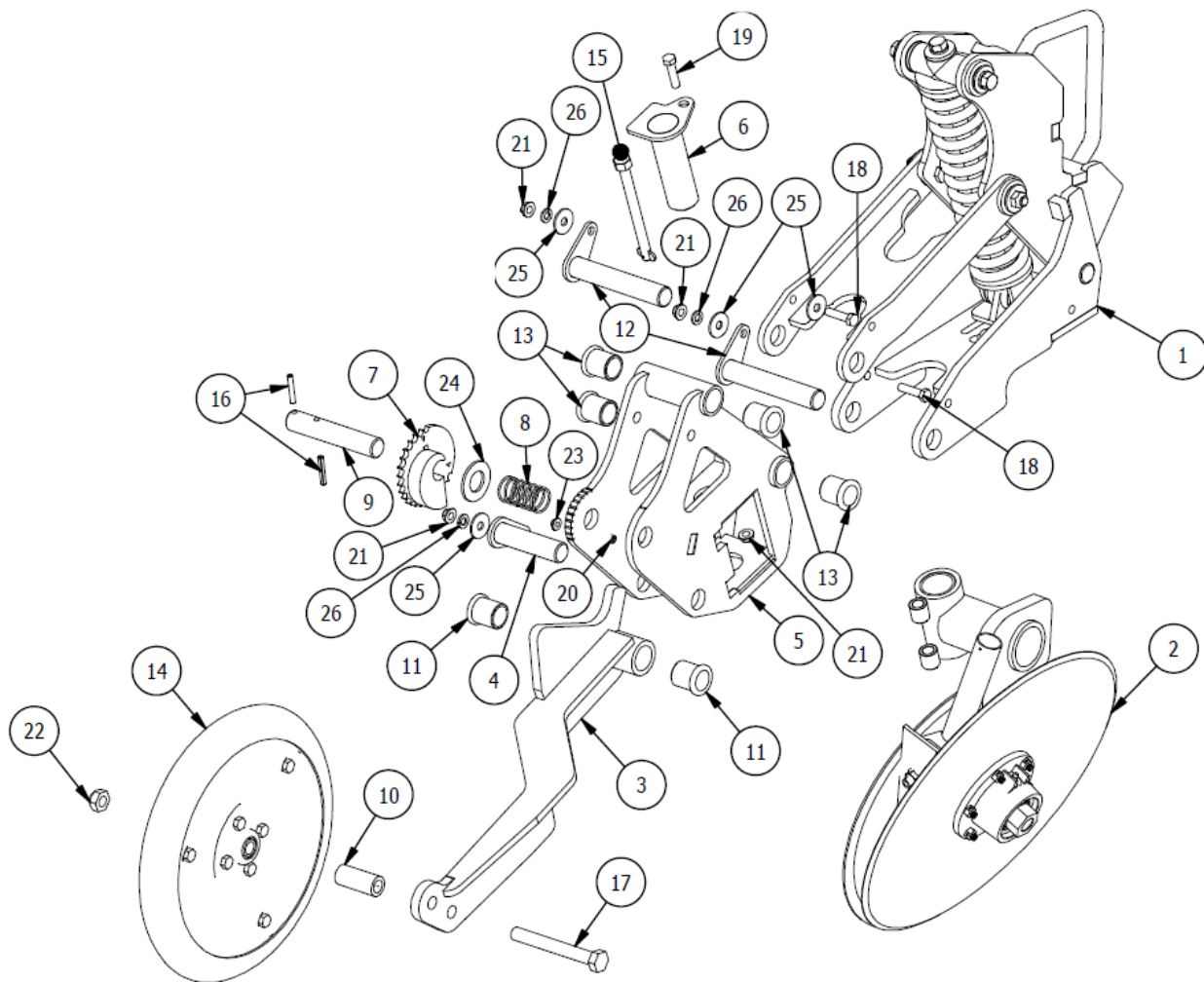

Assembly and Parts

679650: 8612 Opener Assembly, Right —RST

Item	Part No	Rev	Description	Qty
1	678400	0	PARALINK LINKAGE ASSEMBLY	1
2	678260	0	GENT OPENER ASSEMBLY, RH—RST	1
3	677610	0	PAKER ARM WELDMENT, RH—RST	1
4	677605	2	PACKER PIVOT PIN	1
5	677280	0	MOUNT WELDMENT, RH	1
6	677270	2	PIVOT PIN	1
7	497110	1	CAM, RIGHT	1
8	496010	4	SPRING	1
9	493142	2	CAM STOP SHAFT	1
10	493120	1	PACKER WHEEL SPACER	1
11	316001	0	BUSHING, 1 ID X 1-1/4 LG, BLACK	2
12	277265	2	PIVOT PIN	2
13	276222	2	BUSHING, 1ID X 1-1/4 LG, WHITE	4
14	WO214VT	1	PACKER WHEEL, 2 X 14 VT CMLPT	1
15	HPL0424	0	HITCH PIN W/ LOCK, 1/4 X 6	1
16	RP0406	0	ROLL PIN 1/4 X 1-1/2	2
17	SB1020C5P	0	BOLT, HEX, 5/8 UNC X 5 GR5 PL	1
18	SB0606CP	0	BOLT, 3/8 UNC X 1-1/2 PL W/ 1/2 THREAD	3
19	SB0604C5P	0	BOLT, HEX, 3/8 UNC X 1 GR5 PL	1
20	SCS0404C	0	BOLT, SOCKET HEAD, 1/4 UNC X 1	1
21	LSF06CCP	0	LOCKNUT, STOVER, 3/8 UNC GR C	4
22	LS10CBP	0	LOCKNUT, STOVER 5/8 UNC GR B PL	1
23	LSF04CFP	0	LOCKNUT, FLANGED, 1/4 UNC GRF	1
24	WF1632134P	0	WASHER, 1 SAE PL	1
25	WF0602019P	0	WASHER, HEAVY, 3/8 PL	4
26	WL06P	0	WASHER, LOCK 3/8 PL	3

******DO NOT OVERTIGHTEN BOLTS******
Tighten to Grade Torque Specifications Pg-15

Assembly and Parts

679655: 8612 Opener Assembly, Left—RST

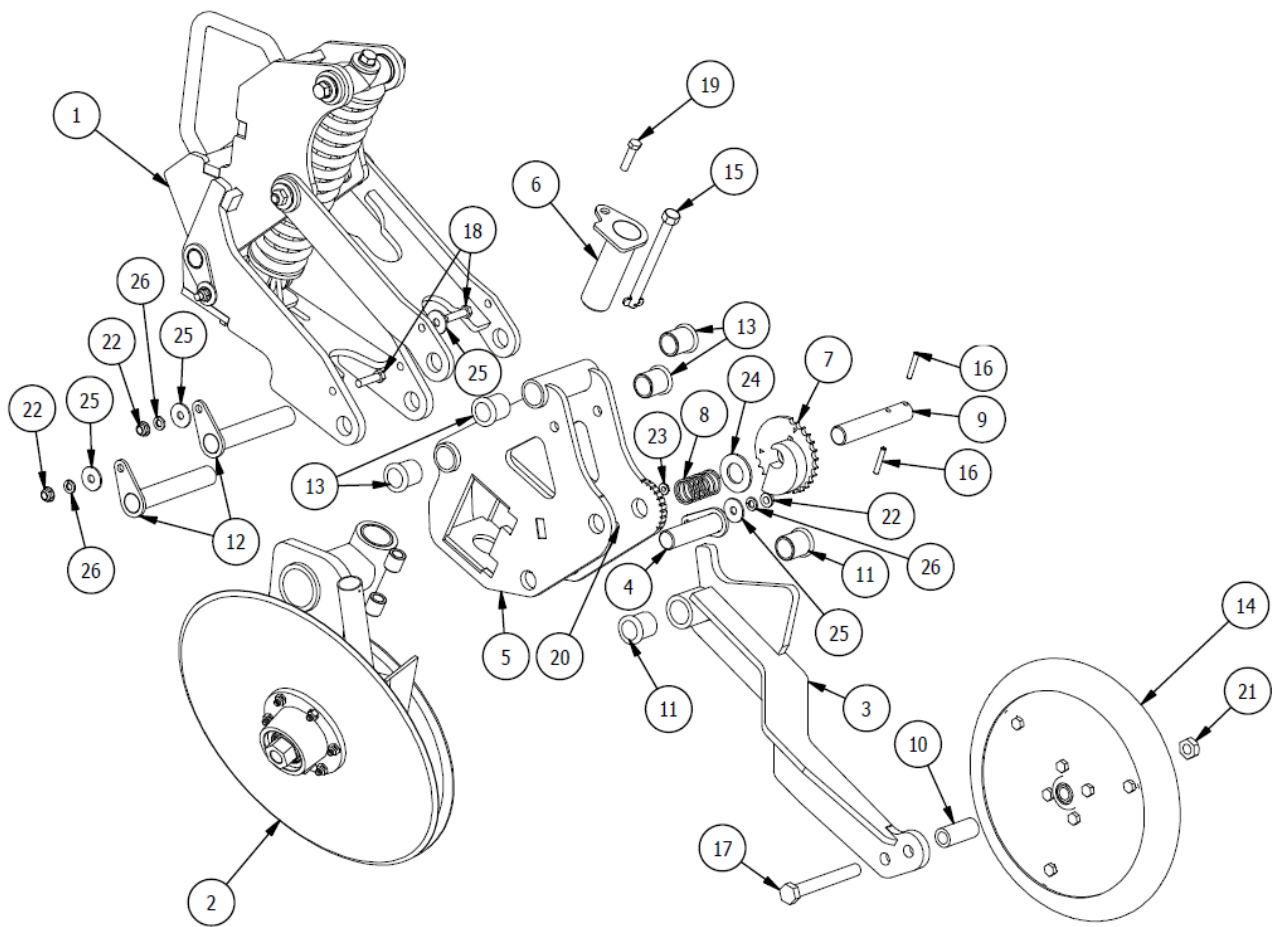

Assembly and Parts

679655: 8612 Opener Assembly, Left—RST

Item	Part No	Rev	Description	Qty
1	678400	0	PARALINK LINKAGE ASSEMBLY	1
2	678265	2	GENT OPENER ASSEMBLY, LH—RST	1
3	677613	2	PACKER ARM WELDMENT, LH—RST	1
4	677605	2	PACKER PIVOT PIN	1
5	677283	2	MOUNT WELDMENT, LH	1
6	677270	2	PIVOT PIN	1
7	497114	1	CAM, LEFT	1
8	496010	4	SPRING	1
9	493142	2	CAM STOP SHAFT	1
10	493120	1	PACKER WHEEL SPACER	1
11	316001	0	BUSHING, 1 ID X 1-1/4 LG, BLACK	2
12	277265	2	PIVOT PIN	2
13	276222	2	BUSHING, 1ID X 1-1/4 LG, WHITE	4
14	WO214VT	1	PACKER WHEEL, 2 X 14 VT CMPLT	1
15	HPL0424	0	HITCH PIN W/ LOCK, 1/4 X 6	1
16	RP0406	0	ROLL PIN 1/4 X 1-1/2	2
17	SB1020C5P	0	BOLT, HEX, 5/8 UNC X 5 GR5 PL	1
18	SB0606CP	0	BOLT, 3/8 UNC X 1-1/2 PL W/ 1/2 THREAD	3
19	SB0604C5P	0	BOLT, HEX, 3/8 UNC X 1 GR5 PL	1
20	SCS0404C	0	BOLT, SOCKET HEAD, 1/4 UNC X 1	1
21	LS10CBP	0	LOCKNUT, STOVER 5/8 UNC GRB PL	1
22	LSF06CCP	0	LOCKNUT, STOVER, 3/8 UNC GRC	4
23	LSF04CFP	0	LOCKNUT, FLANGED, 1/4 UNC GRF	1
24	WF1632134P	0	WASHER, 1 SAE PL	1
25	WF0602019P	0	WASHER, HEAVY, 3/8 PL	4
26	WL06P	0	WASHER, LOCK 3/8 PL	3

******DO NOT OVERTIGHTEN BOLTS******
Tighten to Grade Torque Specifications Pg-15

Assembly and Parts

278310: Spring Assembly

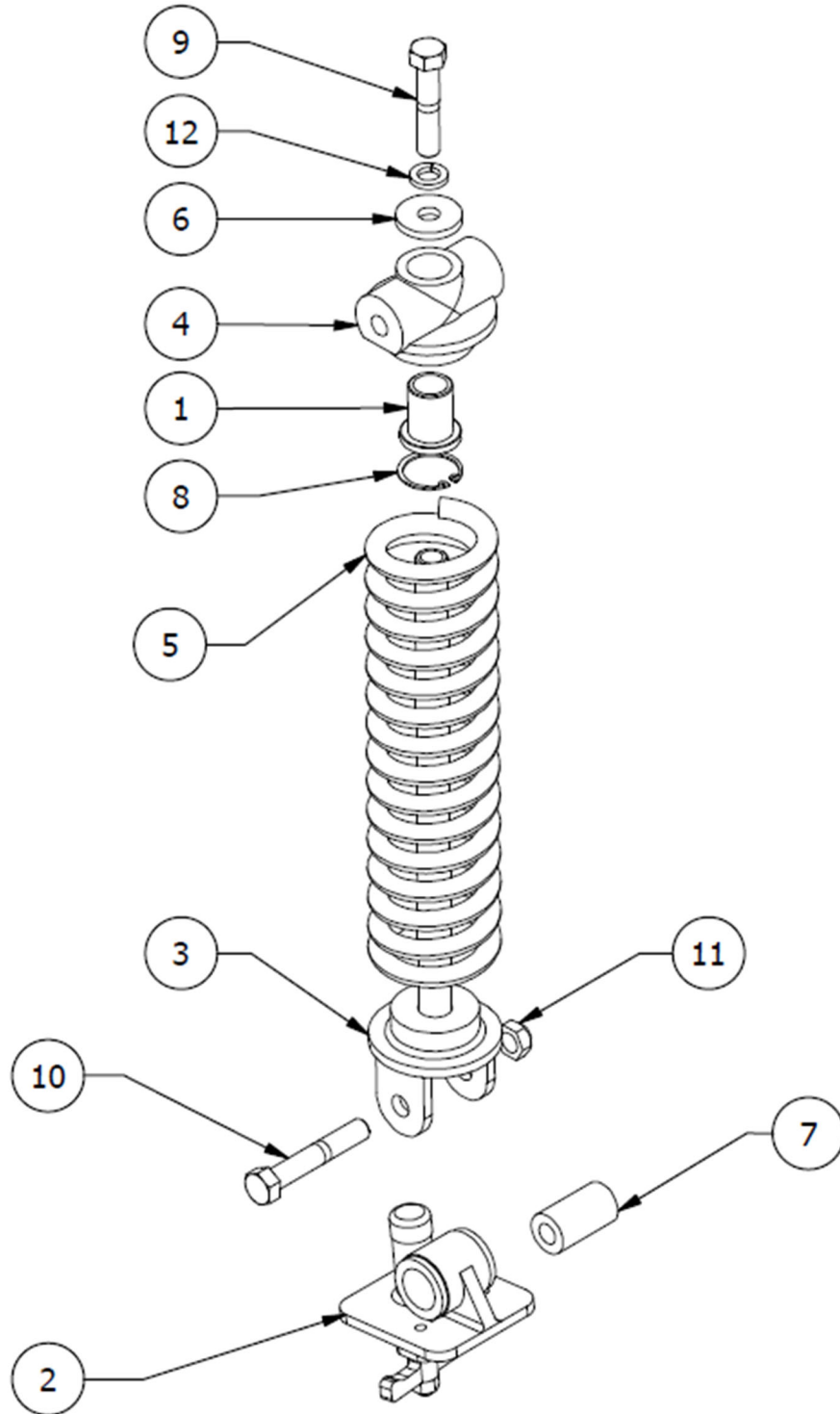

Assembly and Parts

278310: Spring Assembly

Item	Part No	Rev	Description	Qty
1	312098	5	BUSHING, SHOULDER, 3/4 ID	1
2	278280	2	SPRING BASE ASSM	1
3	277270	0	SPRING CENTRE	1
4	276230	3	SPRING HEAD	1
5	276170	0	SPRING, PRESSURE	1
6	273322	0	STOP WASHER	1
7	273312	0	LOWER SPRING PVT SLEEVE	1
8	225111	0	SNAP RING HO-137	1
9	TB0812C8P	0	BOLT, 1/2 UNC X 3 GR8	1
10	SB0810C5P	0	BOLT, 1/2 UNC X 2-1/2 TAP GR5	1
11	LS08CCP	0	LOCKNUT, STOVER, 1/2 UNC GR C	1
12	WL08P	0	WASHER, LOCK 1/2	1

******DO NOT OVERTIGHTEN BOLTS******
Tighten to Grade Torque Specifications Pg-15

Assembly and Parts

278280: Spring Base Assembly

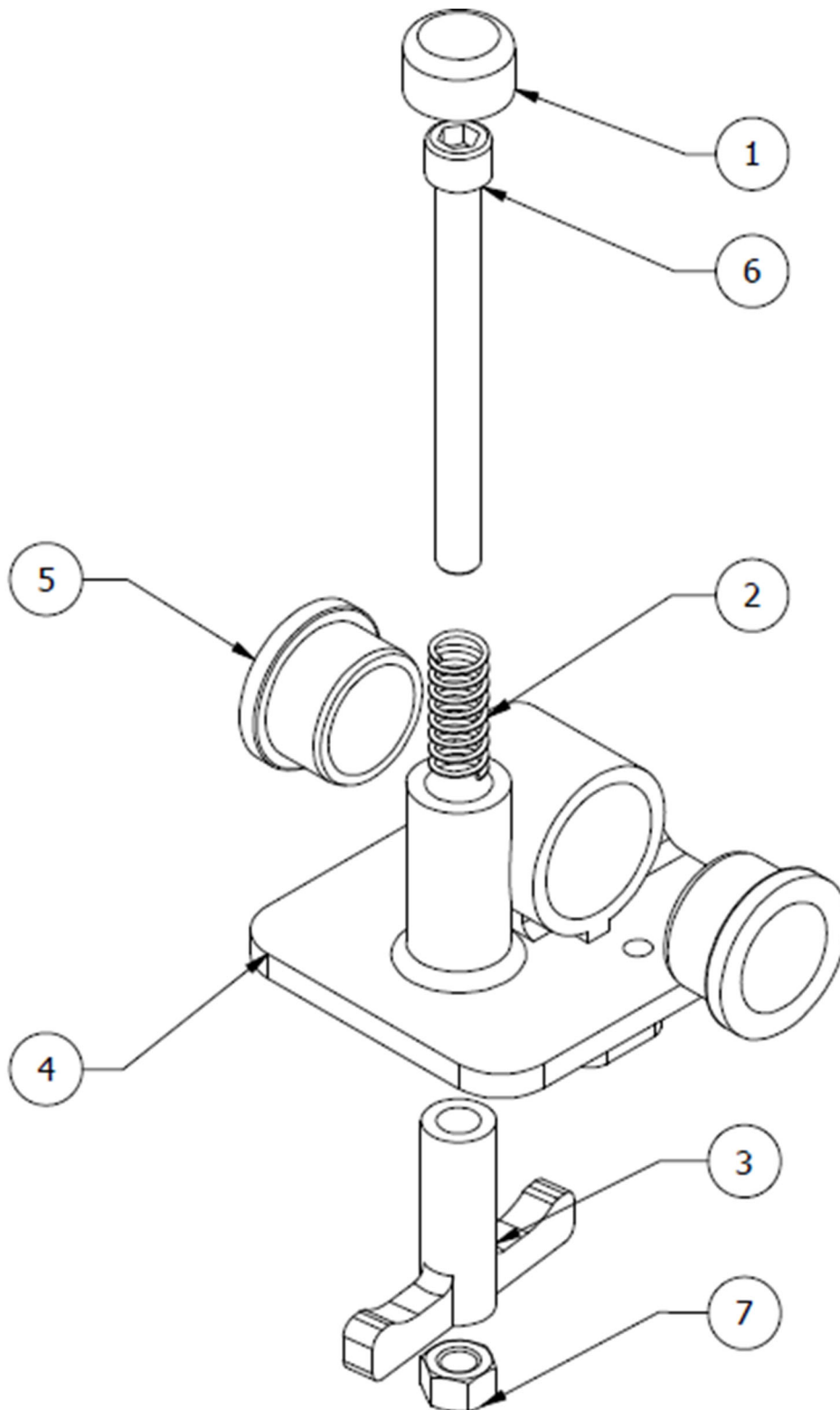

Assembly and Parts

278280: Spring Base Assembly

Item	Part No	Rev	Description	Qty
1	276265	0	CAP, VINYL, 7/8 X 1/2	1
2	276255	0	SPRING, COMP, 0.504 X 1.78 X 17 LB/IN	1
3	276250	1	PULL HANDLE	1
4	276240	2	SPRING LOWER PIVOT	1
5	276220	2	BUSHING, SHOULDER, 1 ID X 1 1/4 OD	2
6	SCS0616C	0	SCREW, SOCKET HEAD CAP, 3/8 UNC X 4	1
7	SN06CCP	0	NUT, LOCK, 3/8 UNC GR C	1

******DO NOT OVERTIGHTEN BOLTS******
Tighten to Grade Torque Specifications Pg-15

Assembly and Parts

678250: Gent Opener Assembly, Right

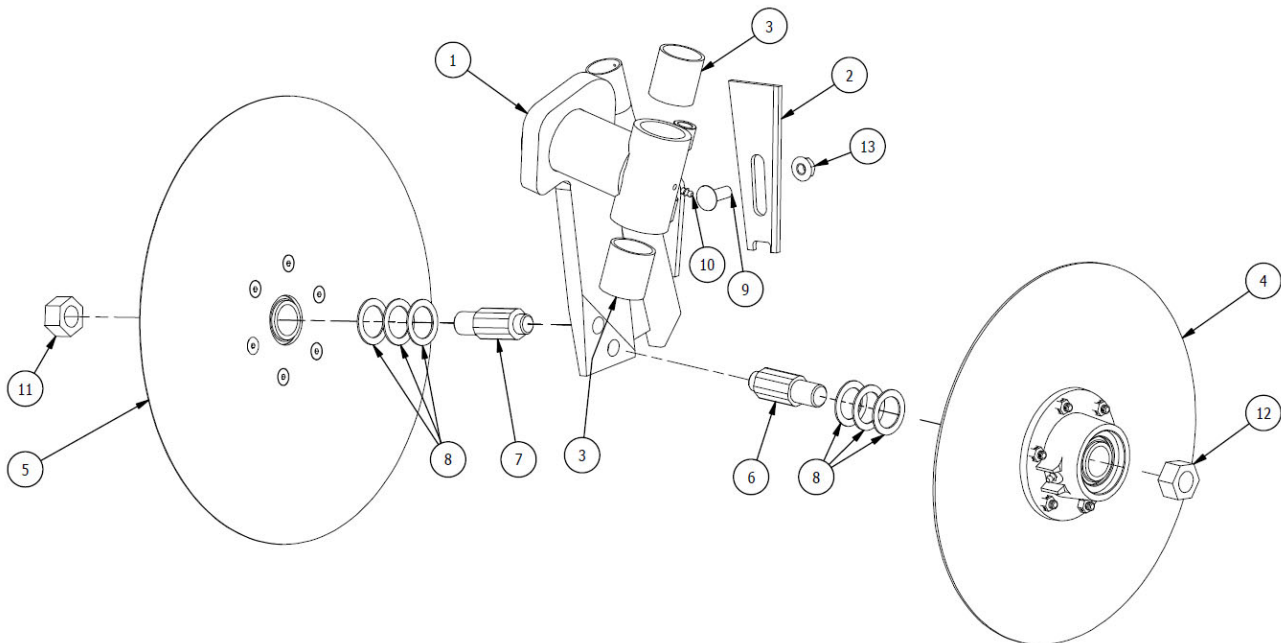

Assembly and Parts

678250: Gent Opener Assembly, Right

Item	Part No	Rev	Description	Qty
1	677260	0	GENT OPENER WELDMENT, RH	1
2	673503	0	MUDSCRAPER, RH	1
3	626050	1	BUSHING 1.5 ID X 1 7/8, BLACK	2
4	268025	0	14.8" DISC ASSEMBLY	1
5	268020	0	17" DISC ASSEMBLY	1
6	150712	7	SPINDLE, LEFT	1
7	150710	7	SPINDLE, RIGHT	1
8	150701	2	SPINDLE WASHER	6
9	CB0705C5P	0	BOLT, CARRIAGE, 1/2 X 1-1/4 UNC GR5 PL	1
10	GN08S	0	GREASE ZERK, STRAIGHT, 1/8-28 NPT	1
11	SN14C5P	0	NUT, 7/8 UNC GR5 PL	1
12	SN14C5PL	0	NUT, 7/8 UNC LH GR5 PL	1
13	HN07C5P	0	NUT, HEX FLANGED, 1/2 UNC GR5 PL	1

******DO NOT OVERTIGHTEN BOLTS******
Tighten to Grade Torque Specifications Pg-15

Assembly and Parts

678255: Gent Opener Assembly, Left

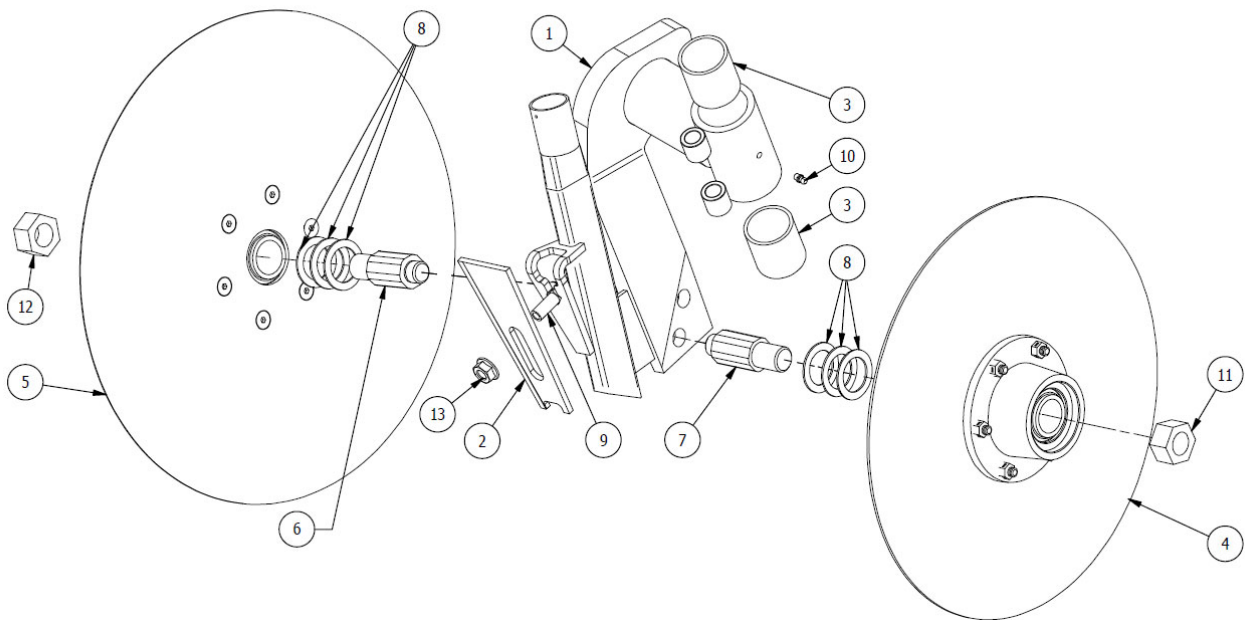

Assembly and Parts

678255: Gent Opener Assembly, Left

Item	Part No	Rev	Description	Qty
1	677263	2	GENT OPENER WELDMENT, LH	1
2	673502	3	MUDSCRAPER, LH	1
3	626050	1	BUSHING 1.5 ID X 1 7/8, BLACK	2
4	268025	0	14.8" DISC ASSEMBLY	1
5	268020	0	17" DISC ASSEMBLY	1
6	150712	7	SPINDLE, LEFT	1
7	150710	7	SPINDLE, RIGHT	1
8	150701	2	SPINDLE WASHER	6
9	CB0705C5P	0	BOLT, CARRIAGE, 1/2 X 1-1/4 UNC GR5 PL	1
10	GN08S	0	GREASE ZERK, STRAIGHT, 1/8-28 NPT	1
11	SN14C5P	0	NUT, 7/8 UNC GR5 PL	1
12	SN14C5PL	0	NUT, 7/8 UNC LH GR5 PL	1
13	HN07C5P	0	NUT, HEX FLANGED, 1/2 UNC GR5 PL	1

******DO NOT OVERTIGHTEN BOLTS******
Tighten to Grade Torque Specifications Pg-15

Assembly and Parts

678260: Gent Opener Assembly, Right —RST

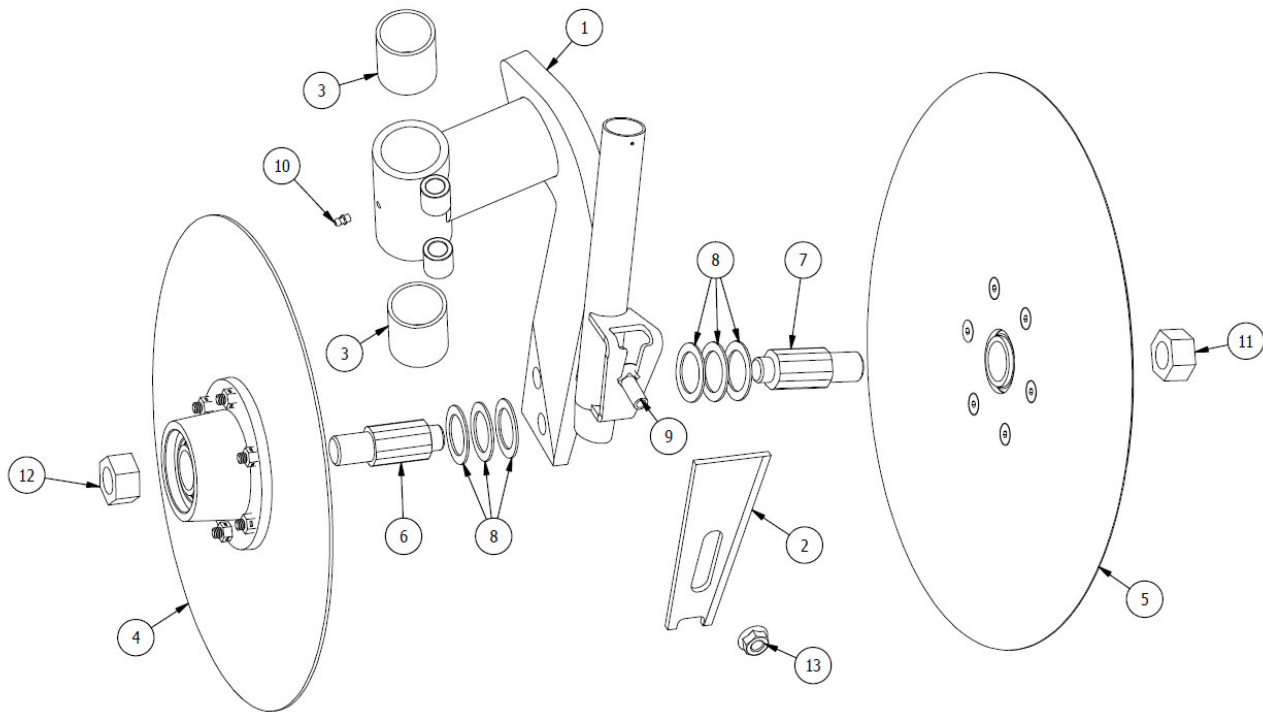

Assembly and Parts

678260: Gent Opener Assembly, Right —RST

Item	Part No	Rev	Description	Qty
1	677240	0	GENT OPENER WELDMENT, RH—RST	1
2	673503	0	MUDSCRAPER, RH	1
3	626050	1	BUSHING 1.5 ID X 1 7/8, BLACK	2
4	268025	0	14.8" DISC ASSEMBLY	1
5	268020	0	17" DISC ASSEMBLY	1
6	150712	7	SPINDLE, LEFT	1
7	150710	7	SPINDLE, RIGHT	1
8	150701	2	SPINDLE WASHER	6
9	CB0705C5P	0	BOLT, CARRIAGE, 1/2 X 1-1/4 UNC GR5 PL	1
10	GN08S	0	GREASE ZERK, STRAIGHT, 1/8-28 NPT	1
11	SN14C5P	0	NUT, 7/8 UNC GR5 PL	1
12	SN14C5PL	0	NUT, 7/8 UNC LH GR5 PL	1
13	HN07C5P	0	NUT, HEX FLANGED, 1/2 UNC GR5 PL	1

******DO NOT OVERTIGHTEN BOLTS******
Tighten to Grade Torque Specifications Pg-15

Assembly and Parts

678265: Gent Opener Assembly, Left —RST

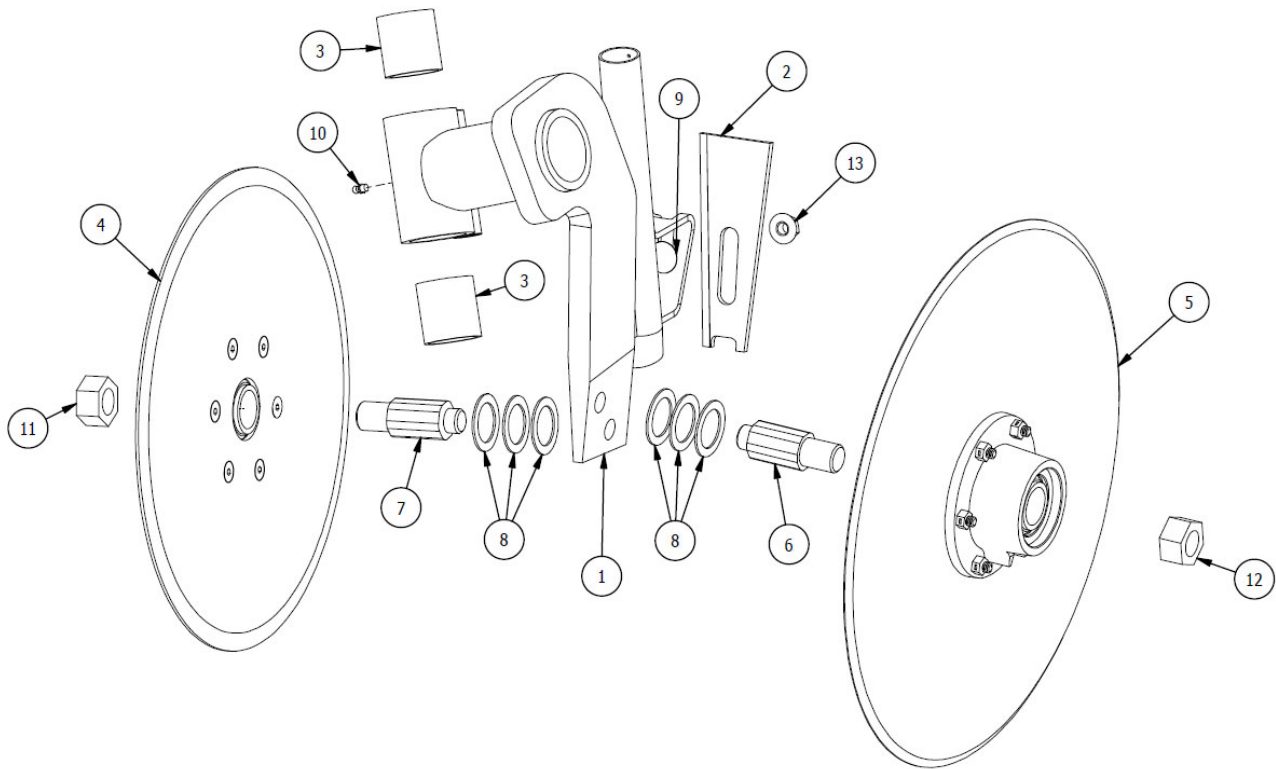

Assembly and Parts

678265: Gent Opener Assembly, Left —RST

Item	Part No	Rev	Description	Qty
1	677243	0	GENT OPENER WELDMENT, LH—RST	1
2	673502	3	MUDSCRAPER, LH	1
3	626050	1	BUSHING 1.5 ID X 1 7/8, BLACK	2
4	268025	0	14.8" DISC ASSEMBLY	1
5	268020	0	17" DISC ASSEMBLY	1
6	150712	7	SPINDLE, LEFT	1
7	150710	7	SPINDLE, RIGHT	1
8	150701	2	SPINDLE WASHER	6
9	CB0705C5P	0	BOLT, CARRIAGE, 1/2 X 1-1/4 UNC GR5 PL	1
10	GN08S	0	GREASE ZERK, STRAIGHT, 1/8-28 NPT	1
11	SN14C5P	0	NUT, 7/8 UNC GR5 PL	1
12	SN14C5PL	0	NUT, 7/8 UNC LH GR5 PL	1
13	HN07C5P	0	NUT, HEX FLANGED, 1/2 UNC GR5 PL	1

******DO NOT OVERTIGHTEN BOLTS******
Tighten to Grade Torque Specifications Pg-15

Assembly and Parts

678400: Paralink Linkage Assembly

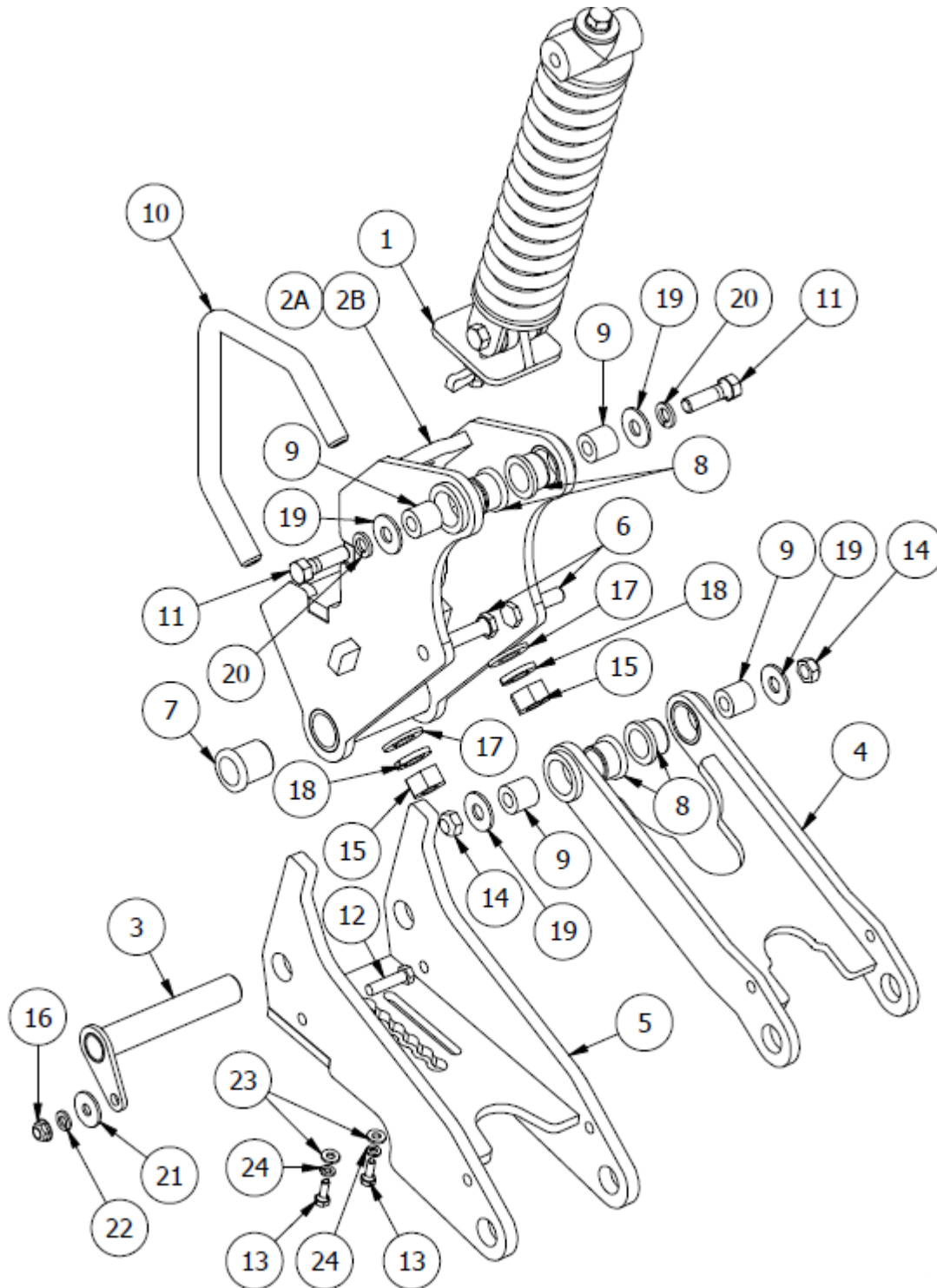

Assembly and Parts

678400: Paralink Linkage Assembly

Item	Part No	Rev	Description	Qty
1	278310	0	SPRING ASSEMBLY	1
2A	277310	1	MOUNT, LONG	1
2B	277280	1	MOUNT, SHORT	1
3	277265	2	PIVOT PIN	1
4	277250	3	UPPER LINK	1
5	277200	4	LOWER LINK	1
6	276270	0	LINKAGE BOLT	2
7	276222	0	BUSHING, 1 ID X 1-1/4 LG, WHITE	2
8	276220	2	BUSHING, SHOULDER, 1 ID X 1 1/4 OD	4
9	273310	0	PIVOT SLEEVE, SHORT	4
10	266004	0	U-BOLT ROOFTOP 6 X 4 X 3/4	1
11	SB0807C8P	0	BOLT, 1/2 UNC X 1-3/4 GR 8	2
12	SB0606CP	0	BOLT, 3/8 UNC X 1-1/2 PL W/ 1/2 THREAD	1
13	SB0403C5P	0	BOLT, 1/4 UNC X 3/4 GR 8	2
14	LS08CCP	0	LOCKNUT, STOVER, 1/2 UNC GR C	2
15	SN12C5P	0	NUT, 3/4 UNC GR 5 PL	2
16	LSF06CCP	0	NUT, LOCK, 3/8 UNC GR C	1
17	WF122413P	0	WASHER, FLAT, 3/4 SAE	2
18	WL12P	0	WASHER, LOCK, 3/4	2
19	WF0822109P	0	WASHER, FLAT, 1/2 USS	4
20	WL08P	0	WASHER, LOCK, 1/2	2
21	WF0602019P	0	WASHER, HEAVY, 3/8 PL	1
22	WL06P	0	WASHER, LOCK, 3/8 PL	1
23	WF0410067P	0	WASHER, FLAT, 1/4 SAE	2
24	WL04P	0	WASHER, LOCK 1/4	2

******DO NOT OVERTIGHTEN BOLTS******
Tighten to Grade Torque Specifications Pg-15

Assembly and Parts

268020: 17" Disc Assembly

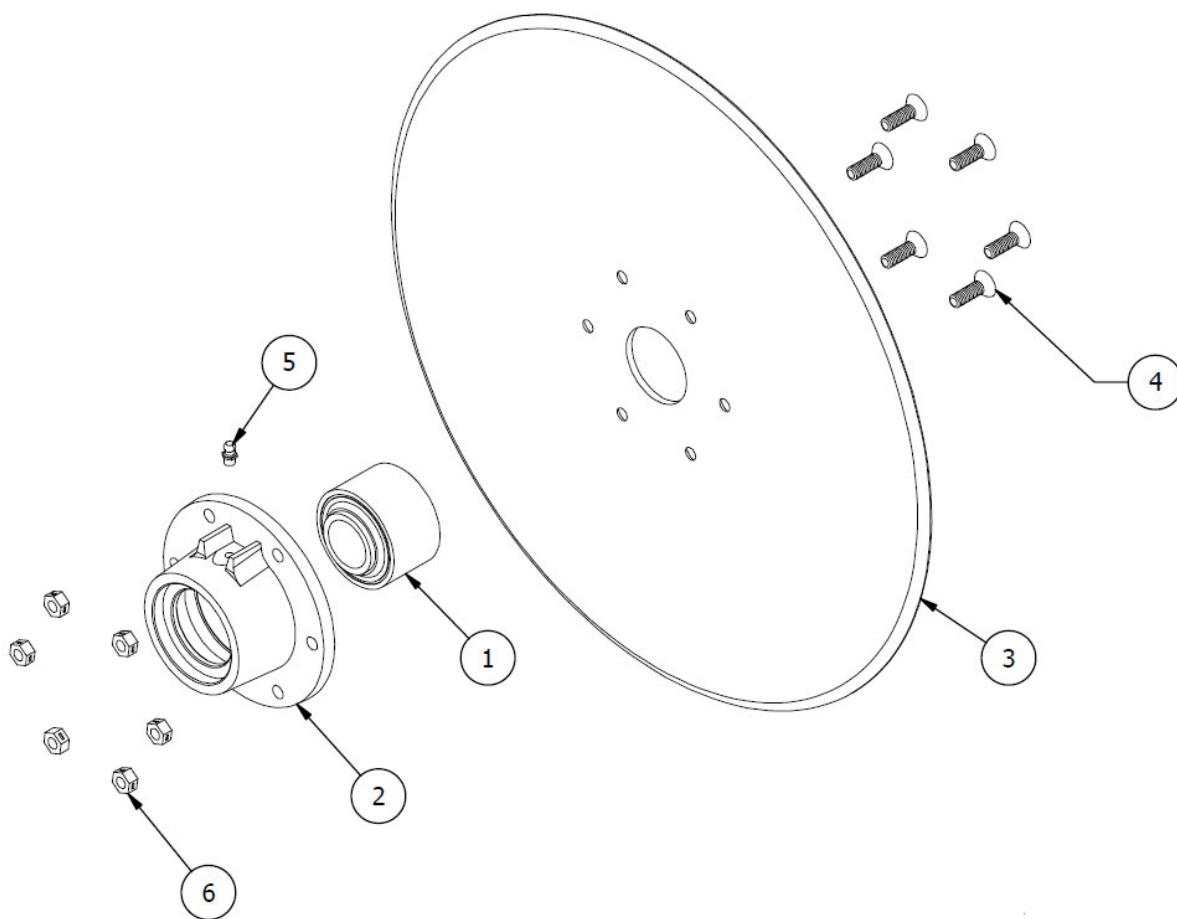

Assembly and Parts

268020: 17" Disc Assembly

Item	Part No	Rev	Description	Qty
1	370960	0	BEARING, DISC	1
2	370950	11	HUB	1
3	370912	0	DISC 17"	1
4	CSSF0504CP	0	BOLT, COUNTERSUNK ALLEN, 5/16 UNC X 1	6
5	GN04S	0	GREASE ZERK, 1/4—28 STRAIGHT	1
6	LR05CP	0	NUT, LOCK, 5/16 UNC GR C	6

******DO NOT OVERTIGHTEN BOLTS******
Tighten to Grade Torque Specifications Pg-15

Assembly and Parts

268025: 14.7" Disc Assembly

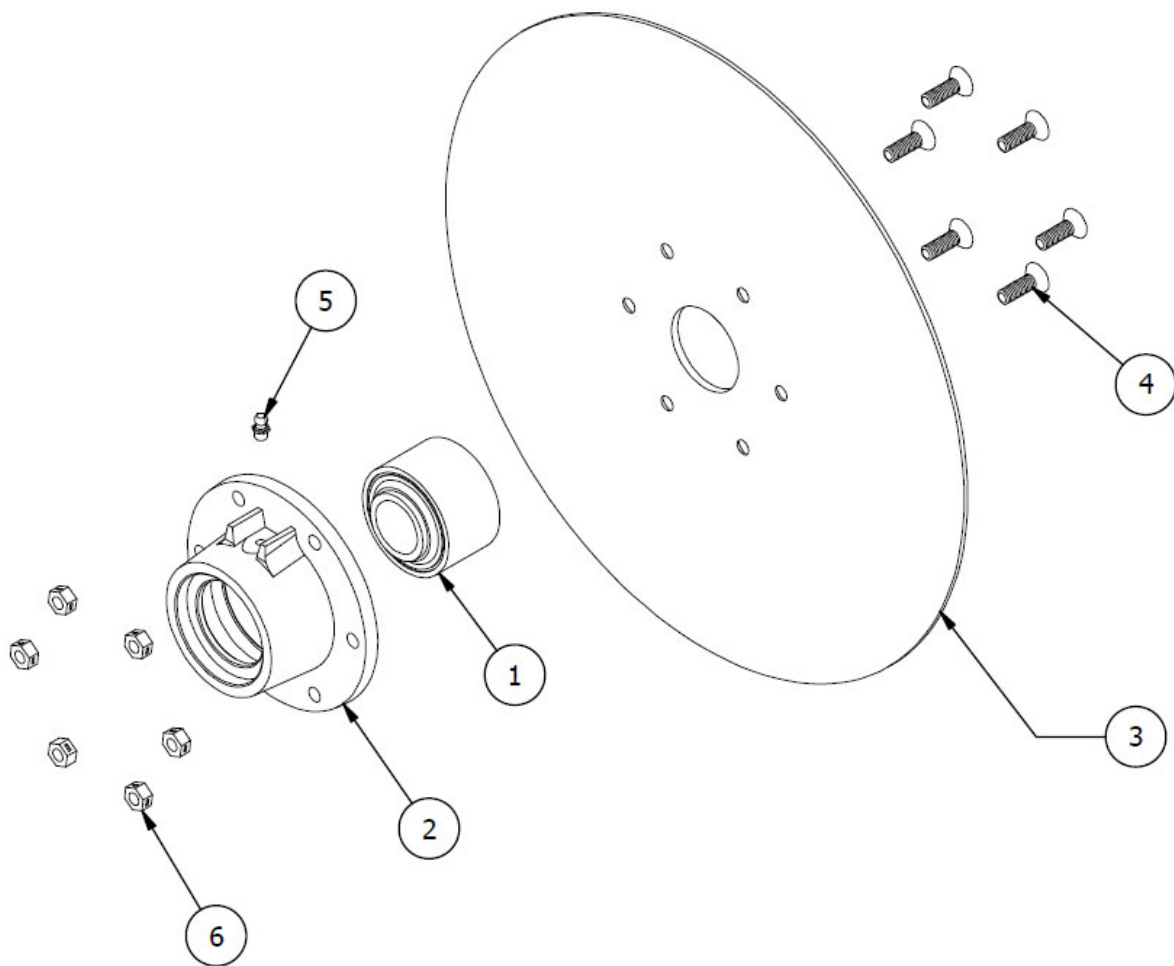

Assembly and Parts

268025: 14.8" Disc Assembly





Item	Part No	Rev	Description	Qty
1	370960	0	BEARING, DISC	1
2	370950	11	HUB	1
3	370908	4	PLAIN FLAT COULTER 14.8" DIA. X 0.177"	1
4	CSSF0504CP	0	BOLT, COUNTERSUNK ALLEN, 5/16 UNC X 1	6
5	GN04S	0	GREASE ZERK, 1/4—28 STRAIGHT	1
6	LR05CP	0	NUT, LOCK, 5/16 UNC GR C	6

******DO NOT OVERTIGHTEN BOLTS******
Tighten to Grade Torque Specifications Pg-15

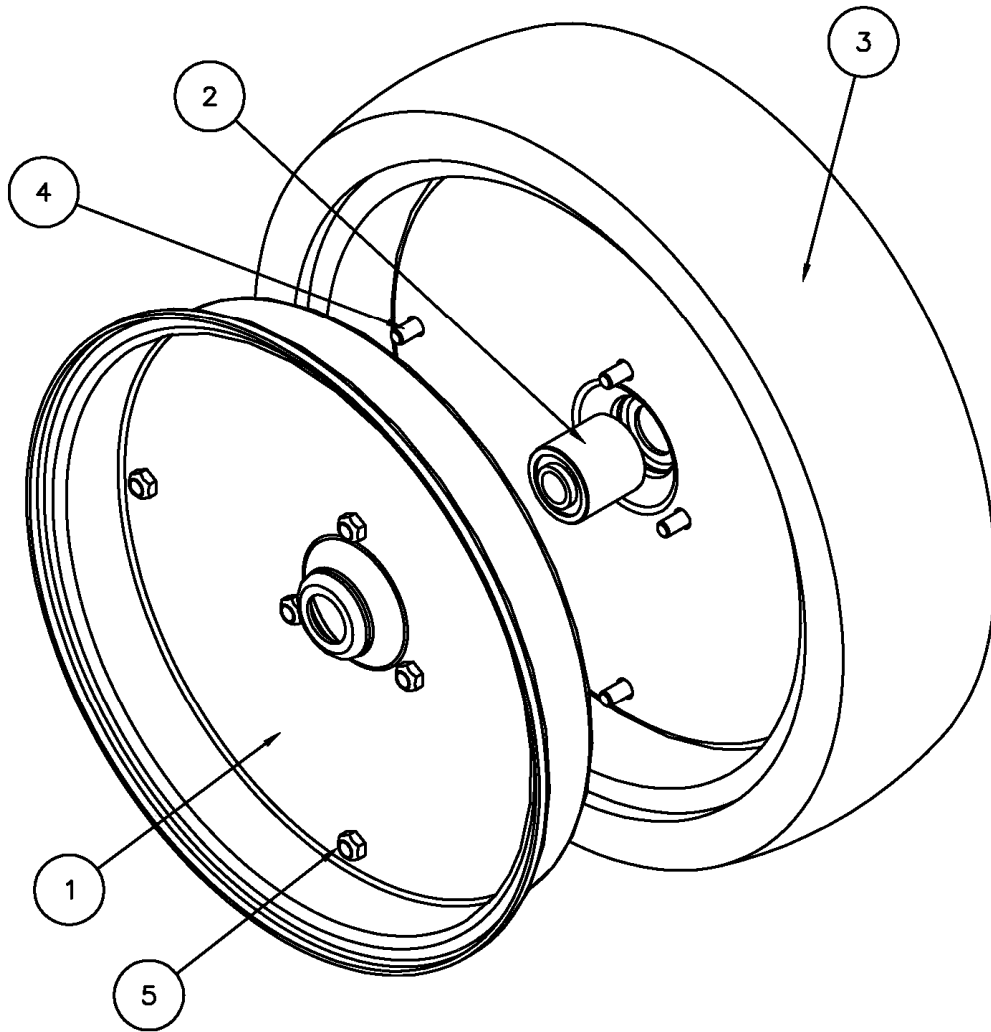
Assembly and Parts

Wheels



Flat Tread	V-Tread	Double Rib	Single Rib
			

Assembly and Parts

Wheels

Item	Part No	Rev	Description	Qty	Price
2	326150	0	BEARING *ONLY WHEEL PART THAT IS SOLD SEPERATELY	1	
	WO416FT	0	WHEEL ASSEMBLY 4 X 16 FLAT TREAD (COMPLETE)		
	WO316FT	0	WHEEL ASSEMBLY 3 X 16 FLAT TREAD (COMPLETE)		
	WO216FT	0	WHEEL ASSEMBLY 2 X 16 FLAT TREAD (COMPLETE)		
	WO313FT	0	WHEEL ASSEMBLY 3 X 13 FLAT TREAD (COMPLETE)		
	WO213FT	0	WHEEL ASSEMBLY 2 X 13 FLAT TREAD (COMPLETE)		
	WO316VT	0	WHEEL ASSEMBLY 3 X 16 V TREAD (COMPLETE)		
	WO313VT	0	WHEEL ASSEMBLY 3 X 13 V TREAD (COMPLETE)		
	WO214VT	0	WHEEL ASSEMBLY 2 X 14 V TREAD (COMPLETE)		
	WO313DR	0	WHEEL ASSEMBLY 3 X 13 DOUBLE RIB (COMPLETE)		
	WO313SR	0	WHEEL ASSEMBLY 3 X 13 SINGLE RIB (COMPLETE)		
	WO3.514RT	0	WHEEL ASSEMBLY 3.5 X 14 ROUND (COMPLETE)		

******DO NOT OVERTIGHTEN BOLTS******
Tighten to Grade Torque Specifications Pg-15 of Manual

