



www.khartindustries.com

Packer Systems

30 Series

Owners Manual

Box 520
Elrose, Saskatchewan S0L 0Z0
Canada
Ph: (306)378-2258
Fax: (306)378-2926
E-mail: sales@khartindustries.com

In Australia:

DIRECT SEEDING AND HARVEST EQUIPMENT
RMB 94 Wellstead via.
Manypeaks WA 6328
Ph: 898 471 022
Contact: Darryl Hine
E-mail: directseeding@wn.com.au

326532 Rev. 2
Updated Jan 2005

This page intentionally left blank

Safety	4
Warranty.....	5
Assembly and Parts	7
General	7
S30	8
WA30.....	10
9910	12
Wheels.....	14
Harrows	16
Setup	18
Operation.....	22
Maintenance.....	23
Notes	24

Safety



With rear mounted packer system, balance of cultivator will be affected. Use caution to avoid upset, especially when climbing steep approaches with cultivator in transport position.



When removing a spring ensure all energy is released before freeing the spring. Failure to do so may result in serious injury.



Do not walk near or under the packer when folded in transport.

The 30 Series packer should be mounted securely to a mounting cross tube by means of the U-Bolts provided. The TA490 main mount arms also need to be mounted to the cultivator frame securely.

Care should be taken when adjusting the packers as the spring will resist upward movement. Keep all body parts away from under the packers and harrows.

Keep all bolts properly tightened.

**ATTENTION:
DO NOT BACK UP WITH THE PACKERS ON THE GROUND.
SEVERE DAMAGE TO THE PACKER ASSEMBLIES MAY RESULT
AND VOIDS ANY WARRANTY.**

K-Hart's objective is to insure that all owners obtain maximum reliability and performance from all K-Hart products.

K-Hart Industries warrants your K-hart products to be free of defects in material and workmanship, under normal use and service. Obligations under this warranty shall extend for a period of 1 year following the date of delivery to the original purchaser and shall be limited to, at the option of K-hart Industries, replacement or repair of any parts found, upon inspection by K-hart, to be defective.

K-Hart Industries reserves the right to make changes or add improvements at any time without notice or obligation.

Warranty claims

The purchaser claiming under this warranty shall report a warranty claim to his Authorized dealer.

Exclusions and/or Deviations from the Base Warranty

- Rubber packer wheels, when used in excessively rocky conditions and will not be warranted against cuts, scrapes, and abrasions.
- **Limitation of Liability.** In no event shall the owner be entitled to recover for incidental, special or consequential damages such as, but not limited to, loss of crops, loss of profits or revenue, other commercial losses, inconvenience or cost of rental or replacement.
- **Normal wear, repair and maintenance not related to defects.** The expressed warranty does not cover wear of components, and is conditional upon the product being properly assembled, adjusted, and operated under normal farming conditions.

This warranty does not cover conditions resulting from misuse, negligence, unauthorized alterations, accident, or lack of performance of required maintenance.

Owner's Obligation



Warranty Transportation Costs. It is the responsibility of the owner, at the owner's expense, to transport the equipment to the service shop of an authorized K-Hart dealer or alternately for any travel or transportation expense involved in fulfilling this warranty.

This page intentionally left blank

Assembly and Parts

General

- Assembly procedure is shown in the following pages. Assembly and parts are shown for all packer systems and options. Your system may not have all the illustrated parts.
- Tighten all bolts to the torques shown in the following table unless otherwise instructed. All u-bolts should be torqued to the Grade 5 specification.
- Due to the multitude of wheel choices, all assemblies are shown without wheels. Refer to the wheel section for wheel options and parts.

Bolt Torque Chart				
Bolt Size	Grade 5 		Grade 8 	
	ft*lbs	N*m	ft*lbs	N*m
1/4	8	11	12	16
5/16	17	23	24	33
3/8	30	41	45	61
7/16	50	68	70	95
1/2	75	102	105	142
9/16	110	149	155	210
5/8	150	203	210	285
3/4	270	366	375	508
7/8	395	536	610	827
1	590	800	910	1234

Assembly and Parts

S30

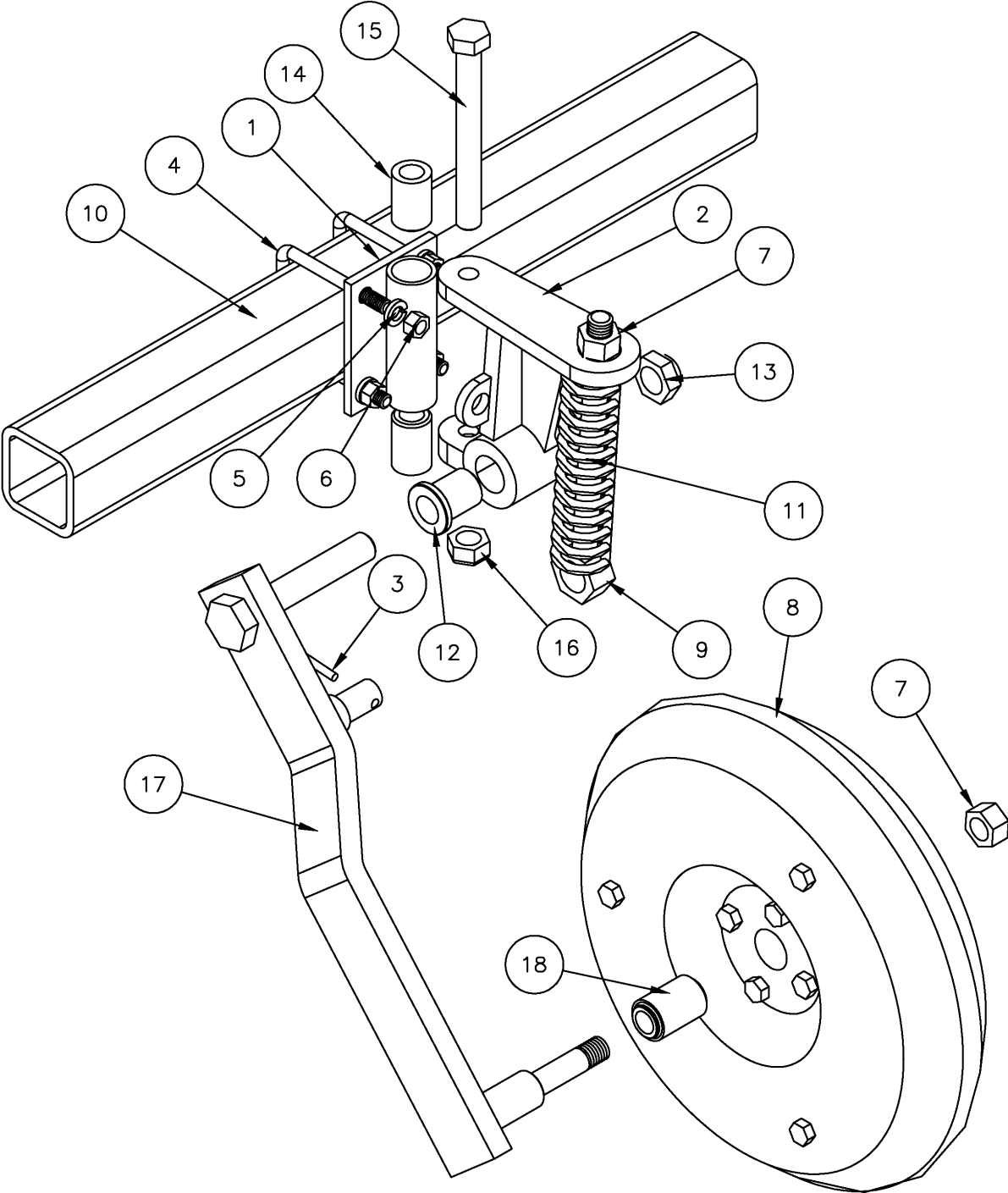

Assembly and Parts

S30

Item	Part No	Rev	Description	Qty
1	304100	0	PIVOT MOUNT	1
2	301027	0	PACKER MOUNT CASTING	1
3	213608	0	COTTER PIN 1/4 X 2 1/2	1
4	306002	0	U-BOLT	2
5	WL06P	0	WASHER LOCK 3/8 PL	4
6	SN06C5P	0	NUT 3/8 UNC GR5 PL	4
7	SN10C5P	0	NUT 5/8 UNC GR5 PL	2
8		0	SEE PAGE 14	1
9	304101	0	SPRING ROD	1
10		0	2 1/2 X 2 1/2 X 0.250W HSS X VARYING LENGTH	
11	304050	5	SPRING	1
12	312098	0	BUSHING	2
13	LS12BCP	0	NUT, STOVER, 3/4 UNC GRB PL	1
14	302014	0	BUSHING 1 OD X 5/8 ID	2
15	SB1024C5P	0	BOLT 5/8 X 6 UNC GR5 PL	1
16	LS10CBP	0	NUT, STOVER LOCK, 5/8 UNC GRB PL	1
17	301107	0	PACKER LEG SINGLE NOTE: THIS REVISION IS NO LONGER PRODUCED. MUST ORDER 301107R5 AND QTY 2 OF 312098. THIS WILL UPDATE TO 50 SERIES SPEC. WILL ALSO REQUIRE NEW PACKER WHEEL BEARING P/N 326150 IF OLD WATERPUMP STYLE P/N 301034 IS IN USE.	1
18	301034 (301035) - NOW 326150	0	2 7/8 PACKER BEARING—PRIOR TO 1997 1 3/4 PACKER BEARING—AFTER 1997	1 1

Assembly and Parts

WA30

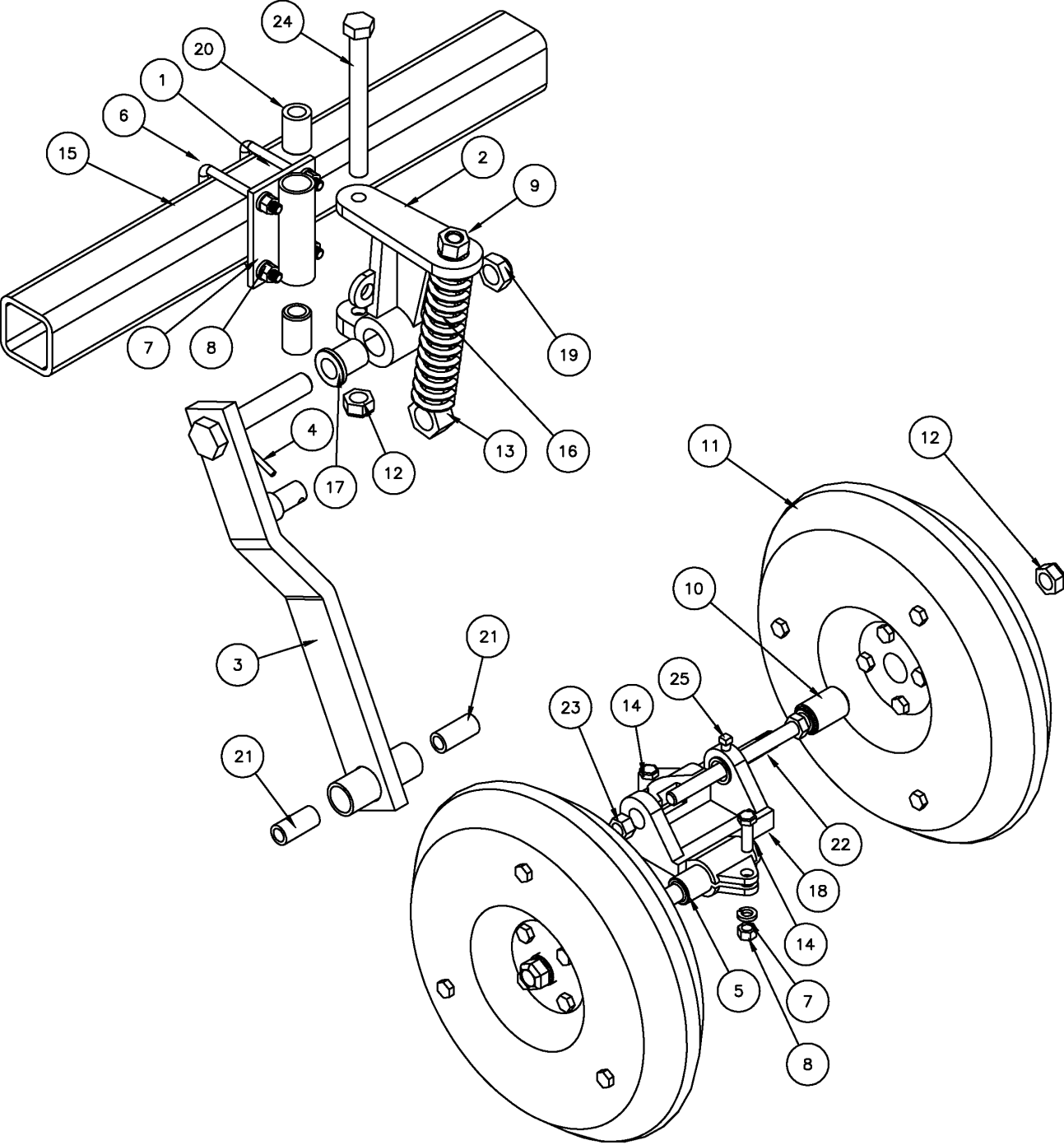

Assembly and Parts

WA30

Item	Part No	Rev	Description	Qty
1	304100	0	PIVOT MOUNT	1
2	301027	0	PACKER MOUNT CASTING	1
3	304102	0	PACKER LEG DOUBLE NOTE: THIS REVISION IS NO LONGER PRODUCED. MUST ORDER 304102R4 AND QTY 2 OF 312098. THIS WILL UPDATE TO 50 SERIES SPEC. WILL ALSO REQUIRE NEW WALKING AXLE CASTING P/N 306004R0, PIN P/N 304008R1, AND 2 BUSHINGS P/N 312098R2. SEE 50 SERIES MANUAL FOR DETAILS ON ASSEMBLY.	1
4	213608	0	COTTER PIN 1/4 X 2 1/2	1
5	304004 304005	1 1	SPINDLE (7-10" SPACING) SPINDLE (9-12" SPACING)	2 2
6	306002	0	U-BOLT	2
7	WL06P	0	WASHER LOCK 3/8 PL	6
8	SN06C5P	0	NUT 3/8 UNC GR5 PL	6
9	SN10C5P	0	NUT 5/8 UNC GR5 PL	1
10	301034 (301035) - NOW 326150	0	2 7/8 PACKER BEARING—PRIOR TO 1997 1 3/4 PACKER BEARING—AFTER 1997	2 2
11		0	SEE PAGE 14	1
12	LS10CBP	0	NUT, STOVER LOCK, 5/8 UNC GRB PL	3
13	304101	0	SPRING ROD	1
14	SB0605C5P	0	BOLT 3/8 X 1 1/4 UNC GR5 PL	2
15		0	2 1/2 X 2 1/2 X 0.250W HSS X VARYING LENGTH	
16	304050	5	SPRING	1
17	312098	0	BUSHING	2
18	304104	0	WALKING AXLE CASTING—CALL FOR AVAILABILITY WHEN INVENTORY IS DEPLETED, MUST UPDATE LEG AS WELL. SEE NOTES FOR ITEM #4.	1
19	LS12C5P	0	NUT, STOVER, 3/4 UNC GRB PL	1
20	302014	0	BUSHING 1 OD X 5/8 ID	2
21	301008	0	BUSHING 3/4 OD X 1/2 ID	2
22	SB0822C5P	0	BOLT 1/2 X 5 1/2 UNC GR5 PL	1
23	SN08C5P	0	NUT 1/2 UNC GR5 PL	1
24	SB1024C5P	0	BOLT 5/8 X 6 UNC GR5 PL	1
25	SQS0503NCP	0	SQ HEAD SET SCREW 5/16 X 3/4 PL	1

Assembly and Parts

9910

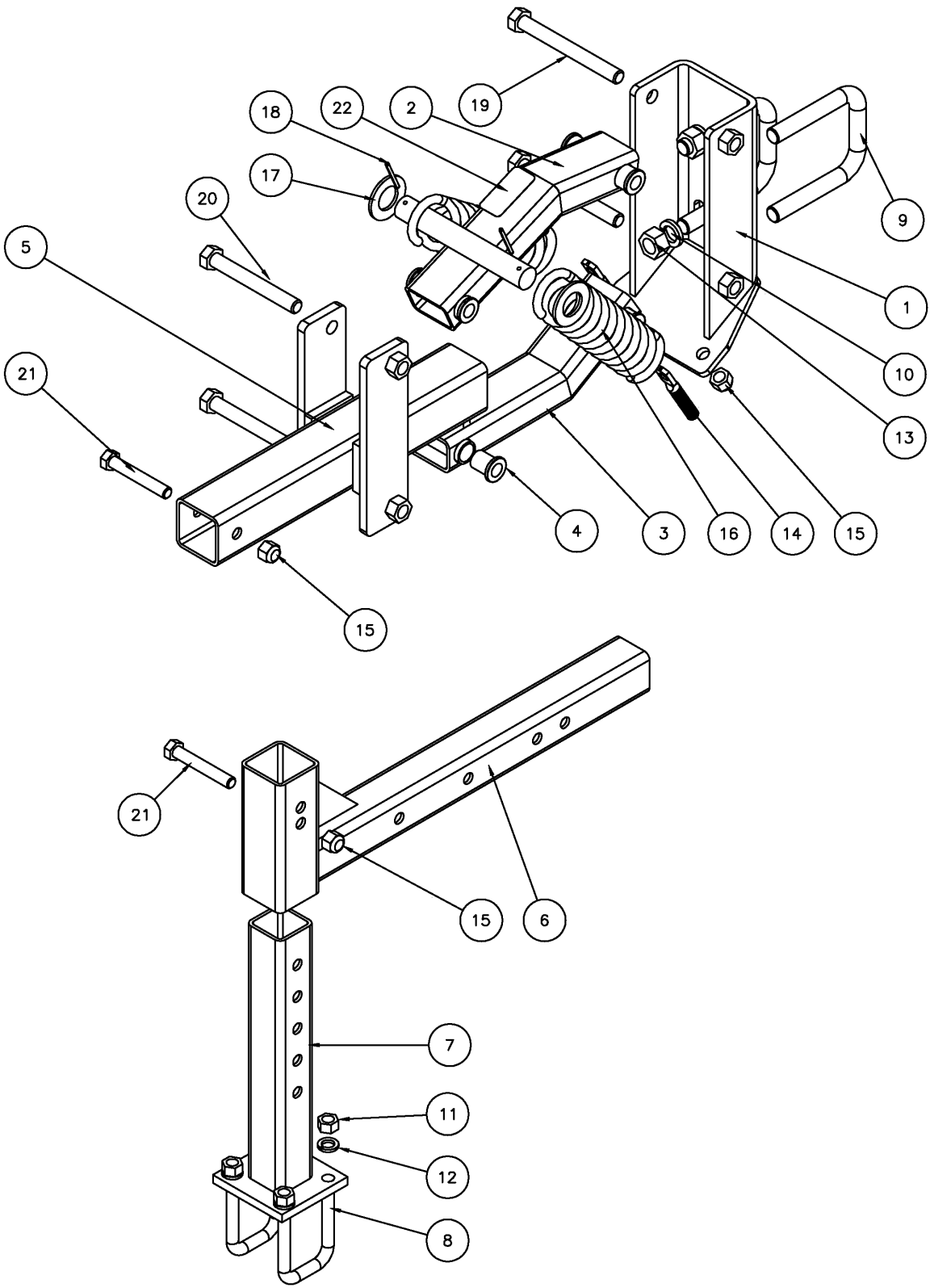

Assembly and Parts

9910

ITEM	NAME	REV	DESCRIPTION	QTY
1	1001740	3	MOUNT	1
2	1001040	1	UPPER LINK ARM	1
3	1000840	1	LOWER LINK ARM	1
4	312098	2	BUSHING	8
5	1000740	2	PIVOT TUBE	1
6	303102	1	ARM EXTENSION	1
7	303103	1	UPRIGHT EXTENSION	1
8	219603	0	U-BOLT 5/8 X 2 9/16 X 4 1/4	2
9	219610 219611	0 0	U-BOLT 7/8 X 4 X 5 3/4 OR U-BOLT 7/8 X 3 1/2 X 5 1/4	2
10	WL14P	0	WASHER LOCK 7/8 PL	4
11	SN10C5P	0	NUT 5/8 UNC GR5 PL	4
12	WL10P	0	WASHER LOCK 5/8 PL	4
13	SN14C5P	0	NUT 7/8 UNC GR5 PL	4
14	312076	1	SPRING BOLT 4"	2
15	LN10C5P	0	NUT, NYLON LOCK 5/8 UNC GR5 PL	4
16	140350	4	SPRING	2
17	WF2040165P	0	WASHER, SAE, 1 1/4 PL	2
18	213607	0	ROLL PIN 3/16 X 2	2
19	SB1228C5P	0	BOLT, 3/4 X 7 UNC GR5 PL	2
20	SB1224C5P	0	BOLT, 3/4 X 6 UNC GR5 PL	2
21	SB1016C5P	0	BOLT, 5/8 X 4 UNC GR5 PL	2
22	316011	0	DECAL K-HART 1 1/2 X 3	1

When installing u-bolts #5 ensure split in lock washer rests on the side of the slot, not in the slot, on the lower leg of the u-bolt.



Do not over-tighten bolt #14. Arm (#2) must move freely.

Tighten nut #13 onto bolt #12 until nut is snug against tubing. Do not over-tighten as tube will be crushed making it difficult to adjust.

Assembly and Parts

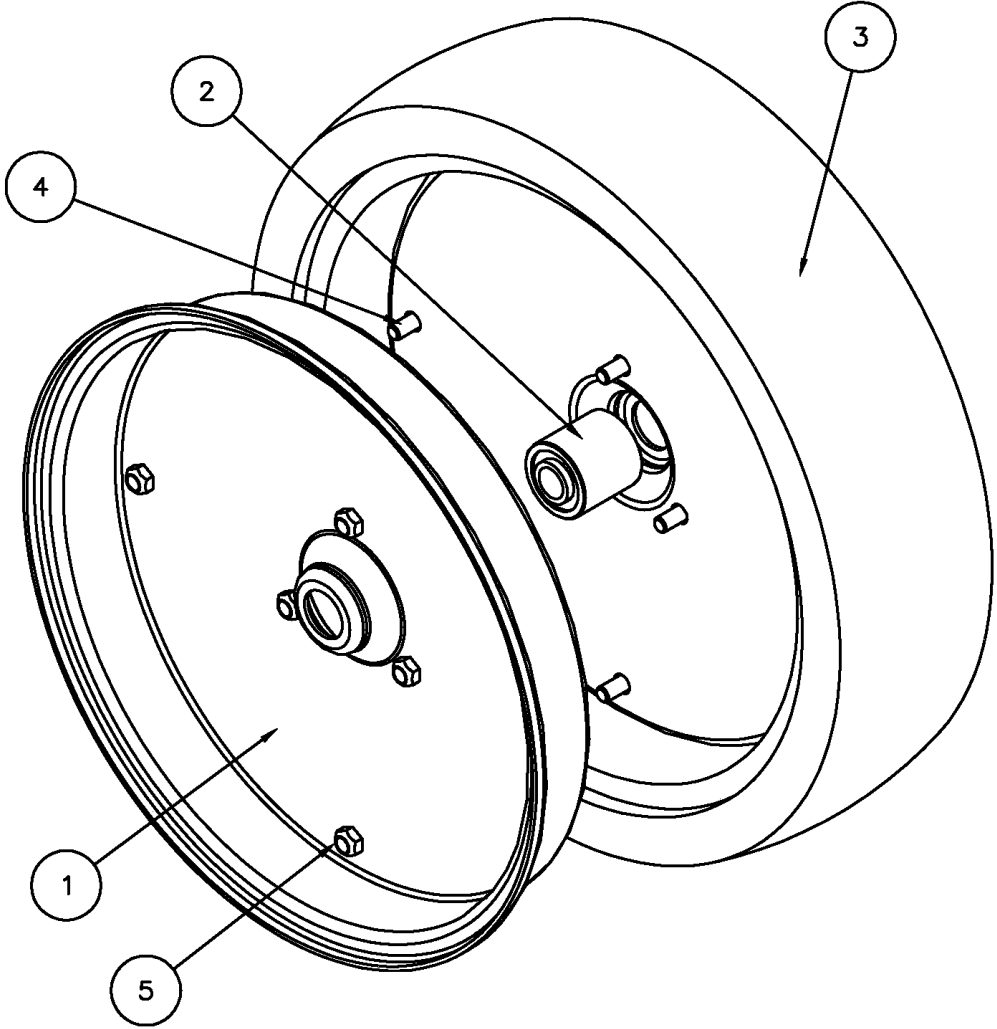
Wheels

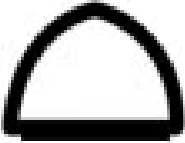

Flat Tread	V-Tread	Double Rib	Single Rib
			

Assembly and Parts

Wheels

Item	Part No	Rev	Description	Qty
1	326100	0	WHEEL HALF 4 X 16	2
	326102	0	WHEEL HALF 3 X 16	
	326103		WHEEL HALF 2 X 16	
	326104		WHEEL HALF 4 X 14	
	326105		WHEEL HALF 3 X 13	
	326106		WHEEL HALF 2 X 14	
	326107		WHEEL HALF 2 X 13	
	326108		WHEEL HALF 4 X 12	
2	326150	0	BEARING	1
3	RO416FT	0	TIRE 4 X 16 FLAT TREAD	1
	RO316FT		TIRE 3 X 16 FLAT TREAD	
	RO216FT		TIRE 2 X 16 FLAT TREAD	
	RO313FT		TIRE 3 X 13 FLAT TREAD	
	RO213FT		TIRE 2 X 13 FLAT TREAD	
	RO412FT		TIRE 4 X 12 FLAT TREAD	
	RO316VT		TIRE 3 X 16 V TREAD	
	RO414VT		TIRE 4 X 14 V TREAD	
	RO313VT		TIRE 3 X 13 V TREAD	
	RO214VT		TIRE 2 X 14 V TREAD	
	RO313DR		TIRE 3 X 13 DOUBLE RIB	
	RO313SR		TIRE 3 X 13 SINGLE RIB	
	RO213SR		TIRE 2 X 13 SINGLE RIB	
	4		SB05025C5P	
5	LS05CCP	0	LOCK NUT 5/16 UNC PL	7
	WO416FT	0	WHEEL ASSEMBLY 4 X 16 FLAT TREAD (COMPLETE)	
	WO316FT	0	WHEEL ASSEMBLY 3 X 16 FLAT TREAD (COMPLETE)	
	WO216FT	0	WHEEL ASSEMBLY 2 X 16 FLAT TREAD (COMPLETE)	
	WO313FT	0	WHEEL ASSEMBLY 3 X 13 FLAT TREAD (COMPLETE)	
	WO213FT	0	WHEEL ASSEMBLY 2 X 13 FLAT TREAD (COMPLETE)	
	WO412FT	0	WHEEL ASSEMBLY 4 X 12 FLAT TREAD (COMPLETE)	
	WO316VT	0	WHEEL ASSEMBLY 3 X 16 V TREAD (COMPLETE)	
	WO414VT	0	WHEEL ASSEMBLY 4 X 14 V TREAD (COMPLETE)	
	WO313VT	0	WHEEL ASSEMBLY 3 X 13 V TREAD (COMPLETE)	
	WO214VT	0	WHEEL ASSEMBLY 2 X 14 V TREAD (COMPLETE)	
	WO313DR	0	WHEEL ASSEMBLY 3 X 13 DOUBLE RIB (COMPLETE)	
	WO313SR	0	WHEEL ASSEMBLY 3 X 13 SINGLE RIB (COMPLETE)	
	WO213SR	0	WHEEL ASSEMBLY 2 X 13 SINGLE RIB (COMPLETE)	

Assembly and Parts

Harrows

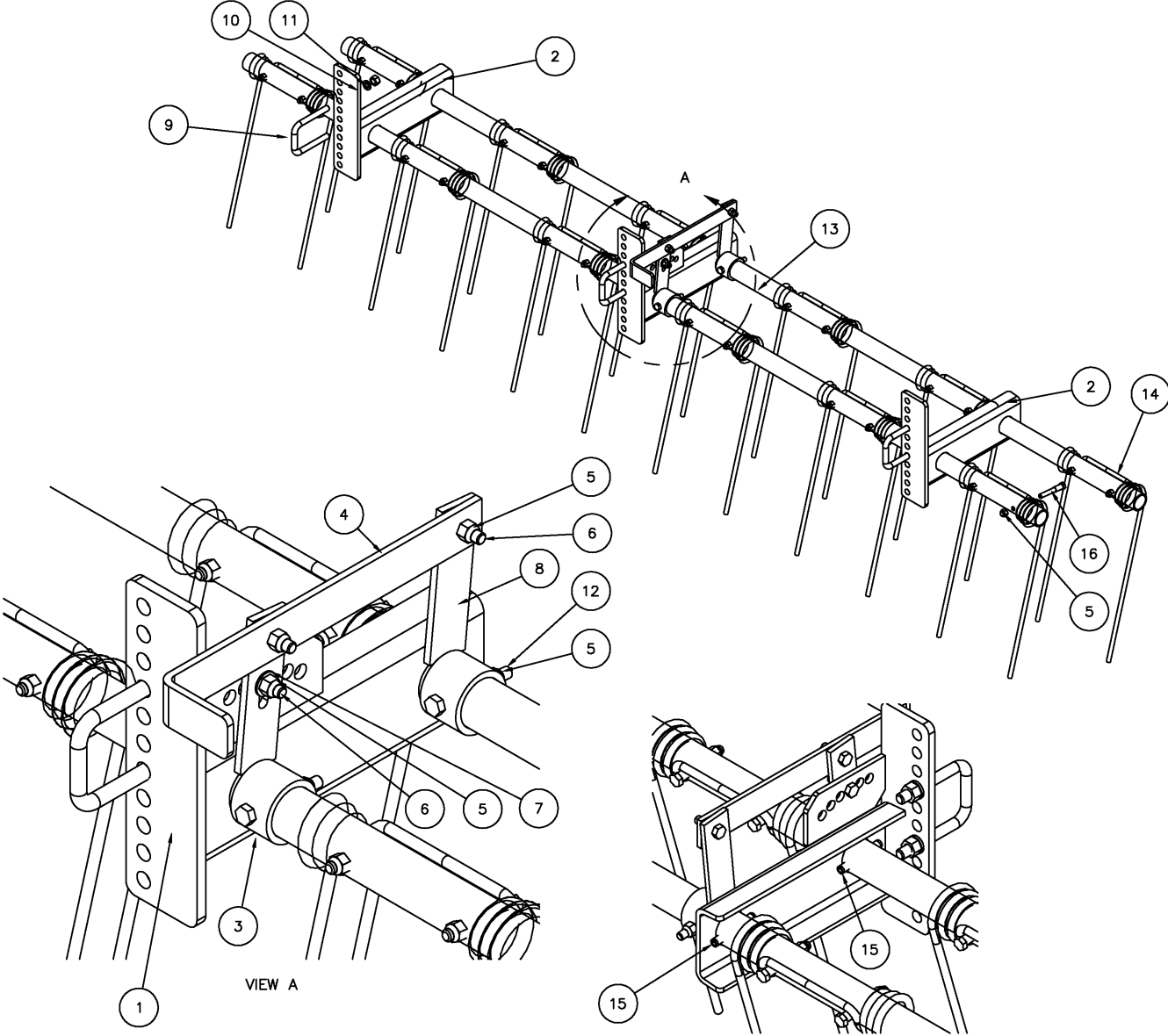

Assembly and Parts

Harrows

ITEM	NAME	REV	DESCRIPTION	QUANTITY/ HARROW SIZE						
				90	108	126	144	162	180	198
1	327001 327010	0	PIPE BRACKET ADJ—AFTER 2004 PIPE BRACKET ADJ—BEFORE 2004	1	1	1	1	2	2	2
2	327002 327011	0	PIPE BRACKET—AFTER 2004 PIPE BRACKET—BEFORE 2004	1	2	2	2	2	2	2
3	327003	0	ANGLE ARM SLOTTED	1	1	1	1	2	2	2
4	323020 323021	0	HANDLE—AFTER 2004 HANDLE—BEFORE 2004	1	1	1	1	2	2	2
5	LN06C5P	0	LOCK NUT NYLON 3/8 UNC PL	25	29	33	37	46	50	54
6	SB0605C5P	0	BOLT, 3/8 X 1 1/4 UNC GR5 PL	3	3	3	3	6	6	6
7	WF0613065P	0	WASHER SAE 3/8 PL	1	1	1	1	2	2	2
8	327004	0	ANGLE ARM	1	1	1	1	2	2	2
9	219609	0	U-BOLT 1/2 X 2 9/16 X 4	2	3	3	3	4	4	4
10	WL08P	0	LOCK WASHER 1/2 PL	4	6	6	6	8	8	8
11	SN08C5P	0	NUT 1/2 UNC GR5 PL	4	6	6	6	8	8	8
12	SB0612C5P	0	BOLT 3/8 X 3 UNC GR5 PL	2	2	2	2	4	4	4
13	303050 303051 303052 303053 303054 303055 303056	0	HARROW PIPE 82 1/2 HARROW PIPE 100 1/2 HARROW PIPE 118 1/2 HARROW PIPE 136 1/2 HARROW PIPE 154 1/2 HARROW PIPE 172 1/2 HARROW PIPE 190 1/2	2	2	2	2	2	2	2
14	326001 326002	0	TINE 9" - AFTER 2004 TINE 8" - BEFORE 2004	10	12	14	16	18	20	22
15	213609	0	SPRING PIN 3/8 X 2 1/2	2	2	2	2	4	4	4
16	326120	0	SHOULDER BOLT PRIOR TO 2004 A 3/8 X 2 1/2 BOLT WITH 2—3/8 NUTS WAS USED.	20	24	28	32	36	40	44

Set-Up

Mounting

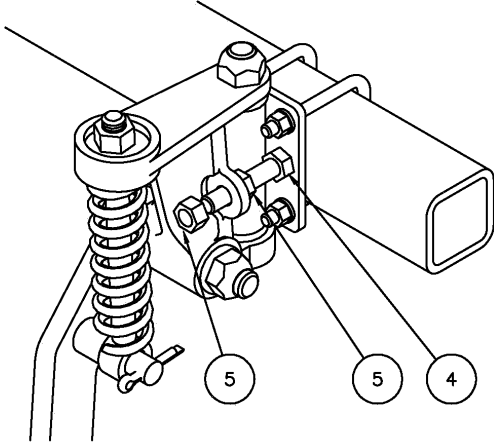
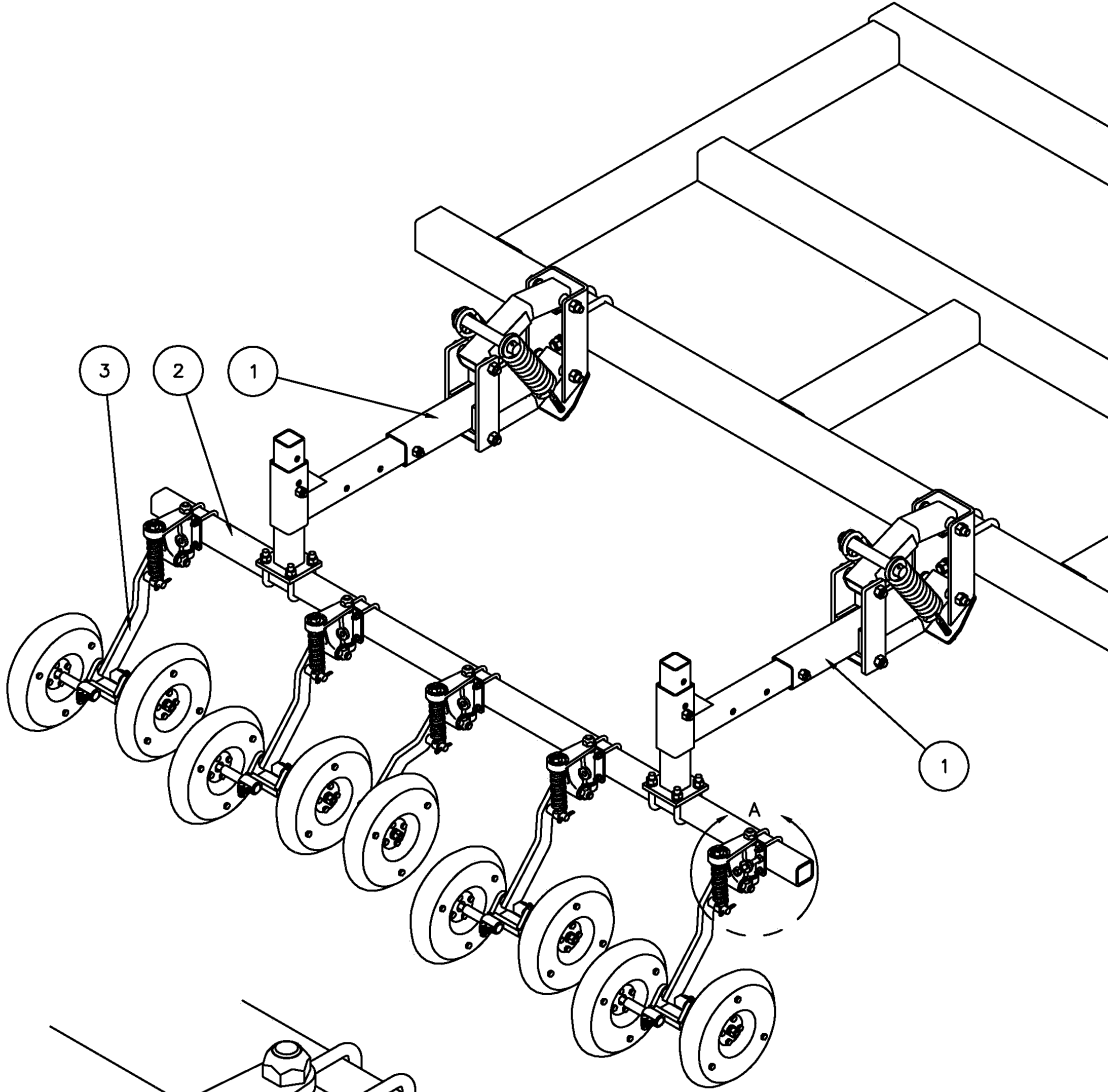

VIEW A

Mounting

Item	Part No	Rev	Description	Qty
1	1001490 1001491		9910 ARM 4" 9910 ARM 3 1/2"	VARIES
2	313200 313201 313208 313202 313203 313204 313205 313206 313207 313209 313210 313211	0 0 0 0 0 0 0 0 0 0 0 0	CROSS TUBING 80 CROSS TUBING 100 CROSS TUBING 105 CROSS TUBING 120 1/2 CROSS TUBING 141 CROSS TUBING 145 CROSS TUBING 160 1/2 CROSS TUBING 167 1/2 CROSS TUBING 181 1/2 CROSS TUBING 95 CROSS TUBING 110 CROSS TUBING 152	VARIES
3	VARIES		PACKER UNITS	VARIES
4	SB0810C5P	0	BOLT, 1/2 X 2 1/2 UNC GR5 PL	VARIES
5	SN08C5P	0	NUT, 1/2 UNC GR5 PL	VARIES

- Mount 9910 main mount arm cap to back of cultivator frame in a position that gives about the same amount of packers to either side of the arm to obtain an even amount of weight distribution
- Assemble Model 9910 main mount arms as per drawing on page 12. **Place bushings in cold water before installing as this will keep the bushings firm and easier to knock in.** The rear extension tube part #303102 can be mounted up or down. Down usually for knife openers and upright for shovels and spoon openers.
- Mount 2 1/2" x 2 1/2" tubing to the 9910 arm with 5/8 x 2 1/2 x 2 1/2" U-bolts.
- Install walking axle casting (part # 304104) using the 1/2" bolt.
- Install packer assemblies with 3/8 x 2 1/2 x 3 1/2" swivel U-bolts to the 2 1/2" tubing.
- Place spindles into walking axle and tighten to the correct spacing with the 3/8 x 1 1/4" bolt and nuts. **DO NOT OVER TIGHTEN BOLTS IN WALKING AXLE CASTING.**
- Install packer wheels on to spindles using 5/8" nut to secure packers in place.
- Place swivel bracket limit bolts(1/2 x 2 1/2") using one bolt for the packer assembly that is on either side of the cultivator hinge joint. See view A on page 18. This limits the packer assembly closest to the hinge joint on the cultivator that when folding in transport, this bolt restricts the packers from swinging down and prevents damage when unfolding the cultivator. Also one bolt goes on the main frame packer to limit the packer from swing open, so when unfolding the wings, this packer does not get

Set-Up

Mounting

damaged.

- The horizontal arm extensions should be retracted as much as practical to keep the weight of the packer system closer to the cultivator. The position selected will depend on a number of factors including:

- The trip distance of the shanks.

- The presence of a ground rod.

- The presence of the optional harrows.

The double packers can be adjusted for spacing by moving the axle in or out of the walking axle casting. **Do not over tighten bolts in walking axle casting.**

Harrows

- Mount harrow support bracket (Part #327002) and adjustment support bracket (Part #327001) on to 2 1/2" tubing using 1/2 x 2 1/2 U-bolts (Part #219609). Use the proper quantities of supports and adjustment brackets as listed on page 17. Install adjustment bracket(s) in the center and the support bracket(s) on either side. Space the brackets as evenly as possible. **Note: Place brackets after packer assemblies have been installed.**
- Slide harrow tubing through the support brackets and install the proper quantity of harrow tines until you have reached the adjustment brackets (Part #327001).
- Install the angle adjustment arm (#327003) and support arm (#327004) as shown in view A on Pg. 16.
- Continue sliding harrow tubing through while installing the required number of harrow tines.
- Install harrow tine bolts.
- Install adjustment handle and linkage bolts.
- Adjust angle adjustment brackets to mid position as shown in view below, and bolt into place.
- Adjust harrow tines in mid angle position. It will be necessary to grab a tine to perform this adjustment. Clamp pipe in this position. Ensure that in the straightest tine position, the tines are a minimum of 5 degrees back.
- Drill 3/8" (10mm) hole through harrow tubing using holes on adjustment brackets #3 and #8 as a guide. Install 3/8 x 3 bolts and nylon locknuts.
- Drill another hole on the backside of the adjustment bracket on both pipes and install the 3/8 roll pins to prevent lateral movement of the front harrow pipe. See detail on Page 16.
- You may wish to cut off the last tine leg (leg only) of the harrows, depending on your configuration and opener size.

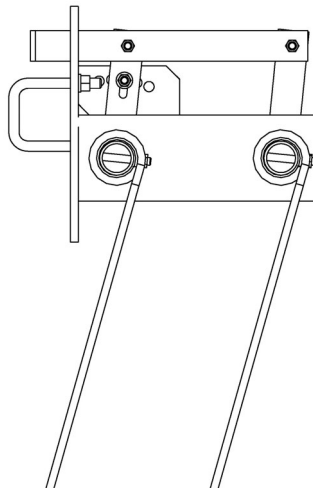

Operation

Packing

The downward pressure of the packers and harrows is adjusted by raising or lowering the vertical upright Part #303103. Initial trial packing force can be set before going to the field. Set the seed openers so they are just touching the top of the ground. Adjust the packer vertical upright Part #303103 so the packers are just touching the ground. In working position, if the packer compression spring Part #304050 is being compressed raising the retaining 5/8" nut Part # SN10C5P about 1" (25 MM) off the top of swivel casting, this generally seems to give adequate packing under most conditions

The distance between the packer wheels on the WA30 double packer system can be adjusted by either exchanging the walking packer spindles for spindles of different lengths or by adjusting the position of the spindles in walking casting.

ATTENTION:

DO NOT BACK UP WITH THE PACKERS ON THE GROUND. SEVERE DAMAGE TO THE PACKER ASSEMBLIES MAY RESULT AND VOIDS ANY WARRANTY.

Note: Although rubber packer wheels self clean better than plastic or steel packers, under certain conditions mud will stick to the rubber wheels. In these cases the soil is generally too wet to be seeding.

Harrows

- Harrow angle can be adjusted using the series of holes in harrow adjustment bracket
- Height adjustment can be made using the series of vertical holes in support and adjustment brackets
- Under heavy or wet straw conditions harrows will have a tendency to drag straw. Under these conditions lay harrow tines back to allow easier straw flow.

Maintenance

Your K-Hart packer system is designed to require very little maintenance. The use of special bushings at all pivot points eliminates daily greasing requirements.

Under certain soil conditions, dirt may pack into the swivel bolt on the packer and make it difficult for the packer to swivel properly. To alleviate this problem, remove the swivel bolt, blow out the housing with compressed air, and re-assemble. If compressed air is not available, drill through bushings with a 5/8" drill bit to help remove build-up of dirt.

Check all mounting bolts on a regular basis to ensure they remain tight.

