



[www.khartindustries.com](http://www.khartindustries.com)

# 3611 Disc Opener

## Owners Manual

Box 520  
Elrose, Saskatchewan S0L 0Z0  
Canada  
Ph: (306)378-2258  
Fax: (306)378-2926  
E-mail: [sales@khartindustries.com](mailto:sales@khartindustries.com)

In Australia:

DIRECT SEEDING AND HARVEST EQUIPMENT  
RMB 94 Wellstead via.  
Manypeaks WA 6328  
Ph: 898 471 022  
Contact: Darryl Hine  
E-mail: [directseeding@wn.com.au](mailto:directseeding@wn.com.au)

326552 Rev. 0  
22-Jul-05

---

---

This page intentionally left blank

# Contents

---

Safety .....	4
Warranty.....	7
Specifications .....	8
Operation.....	9
Maintenance.....	13
Options .....	14
Assembly and Parts.....	15
General .....	15
Packer.....	16
Arm .....	18
Discs.....	20
Mounting.....	22
Wheels.....	24
Mud Scraper .....	26
Residue Manager .....	28
Notes .....	32

# Safety

---

## SAFETY-ALERT SYMBOL



Watch for this symbol. It identifies potential hazards to health or personal safety. It means:

### ATTENTION—BE ALERT Your Safety is Involved

Familiarize yourself with the location of all decals. Read them carefully to understand the safe operation of your machine.

Three words are used in conjunction with the safety-alert symbol:



## DANGER

Indicates an imminently hazardous situation that, if not avoided, will result in death or serious injury.



## WARNING

Indicates a potentially hazardous situation that, if not avoided, could result in serious injury or death.



## CAUTION

Indicates a potentially hazardous situation that, if not avoided, may result in minor or moderate injury.



### Tractor Operation

- Be aware of tractor safety procedure when working with an air drill.
- Review tractor manuals.
- Secure hitch pin with a retainer and lock drawbar in centre position.



### General Operation

- **DO NOT RIDE!!** No one should be allowed to ride on the air drill when in motion.
- No one but the operator in the driver's compartment.
- Check behind when backing up.
- Reduce speed when working in hilly terrain.
- Never allow anyone within the immediate area when working.
- Stand clear when raising or lowering wings.



## Transporting Operation

- When transporting be aware of length, height, and width. Make turns carefully and be aware of obstacles and overhead electrical lines.
- When transporting machine adhere to recommended safe speed. DO NOT EXCEED 20 MPH.
- Do not transport in poor visibility.
- When transporting, be sure transport lock pins are in locking position.
- The slow moving vehicle (SMV) emblem and safety reflectors must be secured on the machine for safe transport
- Check that wings are firmly seated in transport wing stops and lock pins installed.
- Avoid soft surfaces. The additional wing weight on the centre wheels could cause the machine to sink.
- Ensure safety chain is attached correctly.



## Maintenance

- Shut the tractor off before making any adjustments or lubricating the machine.
- Block machine securely when making repairs.
- Wear close-fitted clothing.
- Do not modify the machine.



## Hydraulics

- Do not search for high pressure hydraulic leaks without hand and face protection. A tiny, almost invisible leak can penetrate the skin, requiring immediate medical attention.
- Use cardboard or wood to detect leaks, never your hands!
- Double check that all is clear before operating hydraulics.
- Never remove hoses or hose ends with machine elevated. Ensure all pressure is off of lines to be disassembled.
- Maintain proper hydraulic fluid levels.
- Keep all connectors clean for positive connections.
- Ensure all fittings and hoses are in good repair.
- Do not stand under wings.



## Storage

- Store air drill away from areas of main activity.
- Level air drill and block up securely to relieve pressure on jack.
- Do not allow children to play on or around air drill.

# Safety

Familiarize yourself with the location of all decals. Read them carefully to understand the safe operation of your machine. If any decals become damaged or missing, contact your dealer immediately for a replacement.



**CAUTION**

- READ AND UNDERSTAND THE OPERATORS MANUAL BEFORE OPERATING.
- FOR ROAD TRAVEL, USE FLASHING LIGHTS AND AN SMV SIGN AS REQUIRED. OBSERVE HIGHWAY TRAFFIC REGULATIONS.
- NO RIDERS.

N24301

**TAKE SAFETY SERIOUSLY.**

**DON'T TAKE  
NEEDLESS CHANCES!!**



**CAUTION**

**DO NOT SERVICE  
HYDRAULIC SYSTEM  
WHILE UNDER PRESSURE.**

C-1262



**CAUTION**

**TRANSPORT WHEELS MUST BE  
LOCKED IN PLACE BEFORE  
FOLDING UNIT UP OR DOWN  
AND WHEN TRANSPORTING.  
FAILURE TO DO SO COULD  
RESULT IN SEVERE DAMAGE**

822445



**CAUTION**

**TRANSPORT LOCK  
... MUST BE INSTALLED BEFORE  
TRANSPORTING MACHINE. SEE  
OPERATORS MANUAL.**

F-4644



**DANGER**

- WINGS MAY FALL RAPIDLY CAUSING BODILY INJURY.
- ALWAYS STAY CLEAR OF FOLDING WINGS WHEN BEING RAISED, LOWERED, OR IN ELEVATED POSITION.
- ALWAYS INSTALL ALL LOCKUP DEVICES PROVIDED WHEN WINGS ARE IN ELEVATED POSITION.
- INSURE CYLINDER IS COMPLETELY FILLED WITH HYDRAULIC FLUID TO AVOID UNEXPECTED MOVEMENT.



822445

# Warranty

---

K-Hart's objective is to insure that all owners obtain maximum reliability and performance from all K-Hart products.

K-Hart Industries warrants your K-hart products to be free of defects in material and workmanship, under normal use and service. Obligations under this warranty shall extend for a period of 1 year following the date of delivery to the original purchaser and shall be limited to, at the option of K-hart Industries, replacement or repair of any parts found, upon inspection by K-hart, to be defective.

K-Hart Industries reserves the right to make changes or add improvements at any time without notice or obligation.

## Warranty claims

The purchaser claiming under this warranty shall report a warranty claim to his Authorized dealer.

## Exclusions and/or Deviations from the Base Warranty

- K-Hart does not cover any warranty on the 16.5L-16.1 frame tires. Any warranty has to be dealt with the Original Tire Manufacturer.
- K-Hart does not cover any nicks, cuts, or other marks on the 16.5L-16.1 frame tires that occur during delivery.
- Rubber packer wheels, when used in excessively rocky conditions and will not be warranted against cuts, scrapes, and abrasions.
- **Limitation of Liability.** In no event shall the owner be entitled to recover for incidental, special or consequential damages such as, but not limited to, loss of crops, loss of profits or revenue, other commercial losses, inconvenience or cost of rental or replacement.
- **Normal wear, repair and maintenance not related to defects.** The expressed warranty does not cover wear of components, and is conditional upon the product being properly assembled, adjusted, and operated under normal farming conditions.

This warranty does not cover conditions resulting from misuse, negligence, unauthorized alterations, accident, or lack of performance of required maintenance.

## Owner's Obligation

**Warranty Transportation Costs.** It is the responsibility of the owner, at the owner's expense, to transport the equipment to the service shop of an authorized K-Hart dealer or alternately for any travel or transportation expense involved in fulfilling this warranty.

# Specifications

## 9" Spacing

Width (ft)	Sections	Number of Openers	Approximate Weight base unit (lbs)*		
			Frame	Openers	Total
30	3	40	8400	4800	13200
36	3	48	8900	5760	14660
40	3	53	9200	6360	15560
48	5	64	13000	7680	20680
60	5	80	16200	9600	25800

## 10" Spacing

Width (ft)	Sections	Number of Openers	Approximate Weight base unit (lbs)*		
			Frame	Openers	Total
30	3	36	8400	4320	12720
36	3	42	8900	5040	13940
40	3	48	9200	5760	14960
48	5	58	13000	6960	19960
60	5	72	16200	8640	24840

## 12" Spacing

Width (ft)	Sections	Number of Openers	Approximate Weight base unit (lbs)*		
			Frame	Openers	Total
30	3	30	8400	3600	12000
36	3	36	8900	4320	13220
40	3	40	9200	4800	14000
48	5	48	13000	5760	18760
60	5	60	16200	7200	23400

\*Weights are approximate and will vary depending on options selected. Additional weight can be added.



## Hitching

- Insure your hitch pin is in good condition.
- Position air drill clevis with tractor drawbar using hitch jack.
- After tractor to air drill connection is made, relieve pressure off the hitch jack.
- Pull jack pin. Swing hitch jack parallel to hitch pole and re-pin jack.
- Connect safety chain.

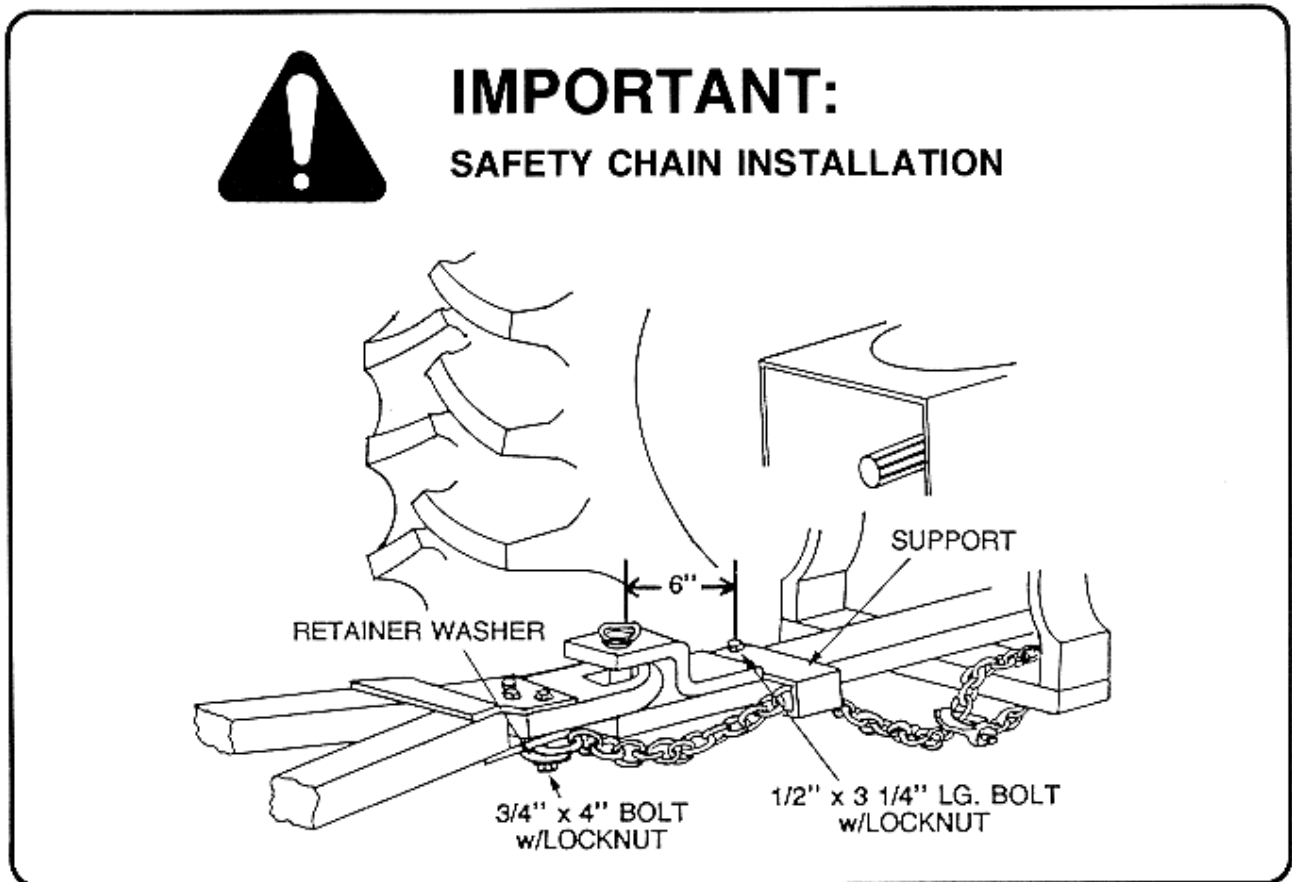

## Hydraulics

- Ensure quick couplers are dirt free.
- **Dirt in the hydraulic system could damage o-rings, causing leakage, pressure loss, and total system failure!**
- Inspect all fittings and hoses for leaks, bends, or kinks.
- Connect the four hydraulic lines. Be sure the wing and depth hoses are matched and connected to the correct valve.

# Operation

---

## Initial Operation

- Make sure that the wheel bolts on the main center frame and the wings are tightened after the first 5 km and then after the next 10 km and the next 20 km during the first few hours of use or transporting. After the initial use, check wheel bolts every 40 hours of operation.

## Leveling

- Initial leveling should be done on a flat, level surface, similar to that of a concrete floor.



- Level frame front to back using the series of holes that are on the hitch.

- Level the wings using the 1" threaded rod that is located on either end of the frame attached to the wing wheel module.



- Be sure that the final adjustment is made under field working conditions. When set properly the disc openers will be working at the same depth from front to back and from side to side.

## Height Adjustment



- On 3-plex machines the height of the frame is controlled by a series of donuts located on the end lift cylinder. Simply add or remove the donuts to set the height.
- On 5-plex machines the height of the frame is controlled by a series of donuts located on the lift cylinders on the center frame. Simply add or remove the donuts to set the height, making sure both cylinders are set the same. This will prevent the rear rockshaft from twisting due to one cylinder traveling farther than the other.

## Setting Openers

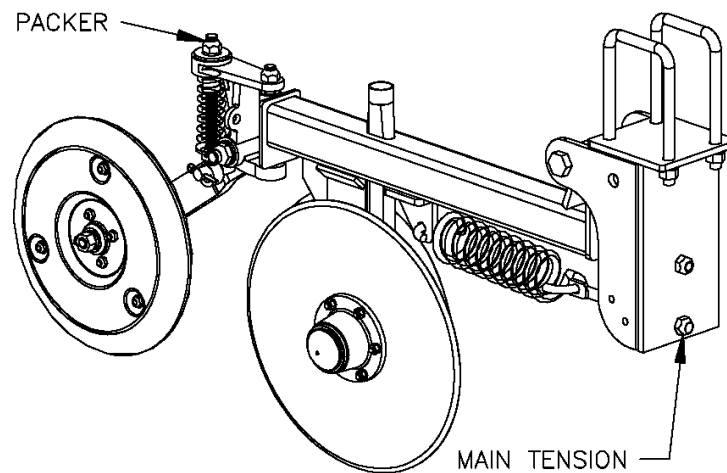

- By adjusting the main tension spring, you will increase the penetrating force of the opener. It is best if you can run the 36 series opener in a horizontal position, giving more uniform packing pressure. This is accomplished by lowering the frame to the required position.
- Packer pressure is set by adjusting the top nut of the packer.
- Travel speed will affect disc penetration and varies upon soil condition, type, and depth of seeding.
- In our experience it is best to tighten the springs so about 1/3 of spring bolt threads are used when unit is off the ground. If main tension spring is too tight, packer will bottom before horizontal position is reached, holding the blades out of the ground.

# Operation

---

## Transporting



- **Use safety locks on main frame and wings when transporting!**
- Do not walk under wings when raised or lowered. Ensure cylinders are completely filled with hydraulic fluid. Entrapped air or hydraulic system failure could cause wings to fall rapidly causing serious injury or death.
- Never exceed 20 mph (32 kph) in transport.

**Use safety lock pins when doing any maintenance on the machine!**

## Frame

### Daily or every 10 hours

- Grease rear rockshaft.

### Weekly or every 50 hours

- Check for and tighten loose wheel bolts.
- Check tire pressure. 16.5 x 16.1 tires should be maintained at a pressure of 48 psi.
- Inspect all hinge pins to ensure they are in place.
- Inspect hydraulic system for leaks, damaged hoses, and loose fittings.

### Annually or every 200 hours

- Grease main wheel hubs.
- Check for any cracked or broken welds.
- Check for and tighten loose wheel bolts.
- Check tire pressure. 16.5 x 16.1 tires should be maintained at a pressure of 48 psi.
- Inspect all hinge pins to ensure they are in place.
- Inspect hydraulic system for leaks, damaged hoses, and loose fittings.

## Openers

### Annually or every 200 hours

- Ensure that all spindle bolts are tight.
- Check for any other loose hardware.
- Check inner blade clearance and remove shims if required. Discs should just touch. Use anti-seize on spindle when replacing so that it is easy to remove the next time.
- Adjust mud scraper clearance.
- Adjust seed deflector clearance.
- Oil blades after the season if desired to keep them from rusting.
- For longest blade life, reverse rear blade with the front blade after the end of the season. It is well worth the time!

# Options

---

## Mud Scraper

- A mud scraper attachment is available for use in sticky soil conditions.

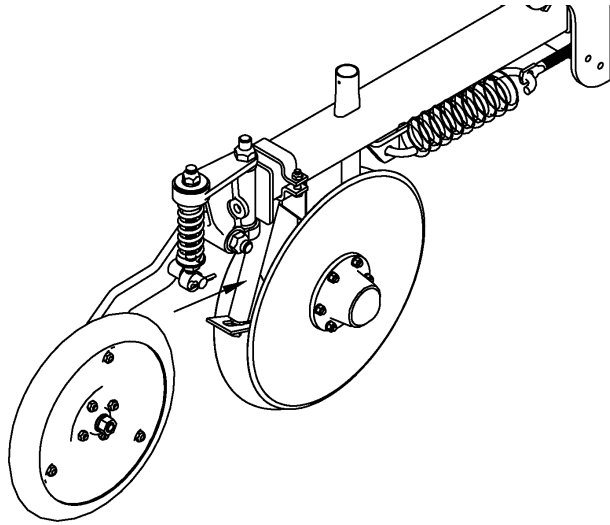

## Residue Manager

- A residue manager may be attached to the opener to help reduce hair-pinning in heavy residue.

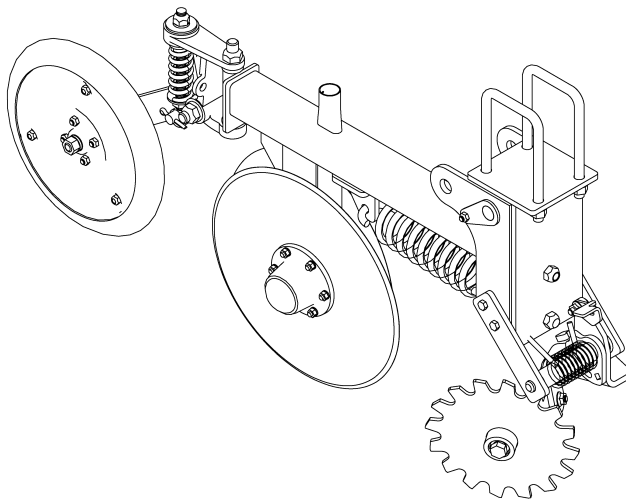



## Blades

- Larger 17" blades are available. They are generally used on openers behind the tractor tires.

## General

- Assembly procedure is shown in the following pages. Assembly and parts are shown for all options. Your system may not have all the illustrated parts.
- Tighten all bolts to the torques shown in the following table unless otherwise instructed. All u-bolts should be torqued to the Grade 5 specification.
- Due to the multitude of wheel choices, all assemblies are shown without wheels. Refer to the wheel section for wheel options and parts.

<b>Bolt Torque Chart</b>				
<b>Bolt Size</b>	<b>Grade 5 </b>		<b>Grade 8 </b>	
	<b>ft*lbs</b>	<b>N*m</b>	<b>ft*lbs</b>	<b>N*m</b>
<b>1/4</b>	8	11	12	16
<b>5/16</b>	17	23	24	33
<b>3/8</b>	30	41	45	61
<b>7/16</b>	50	68	70	95
<b>1/2</b>	75	102	105	142
<b>9/16</b>	110	149	155	210
<b>5/8</b>	150	203	210	285
<b>3/4</b>	270	366	375	508
<b>7/8</b>	395	536	610	827
<b>1</b>	590	800	910	1234

# Assembly and Parts

## Packer

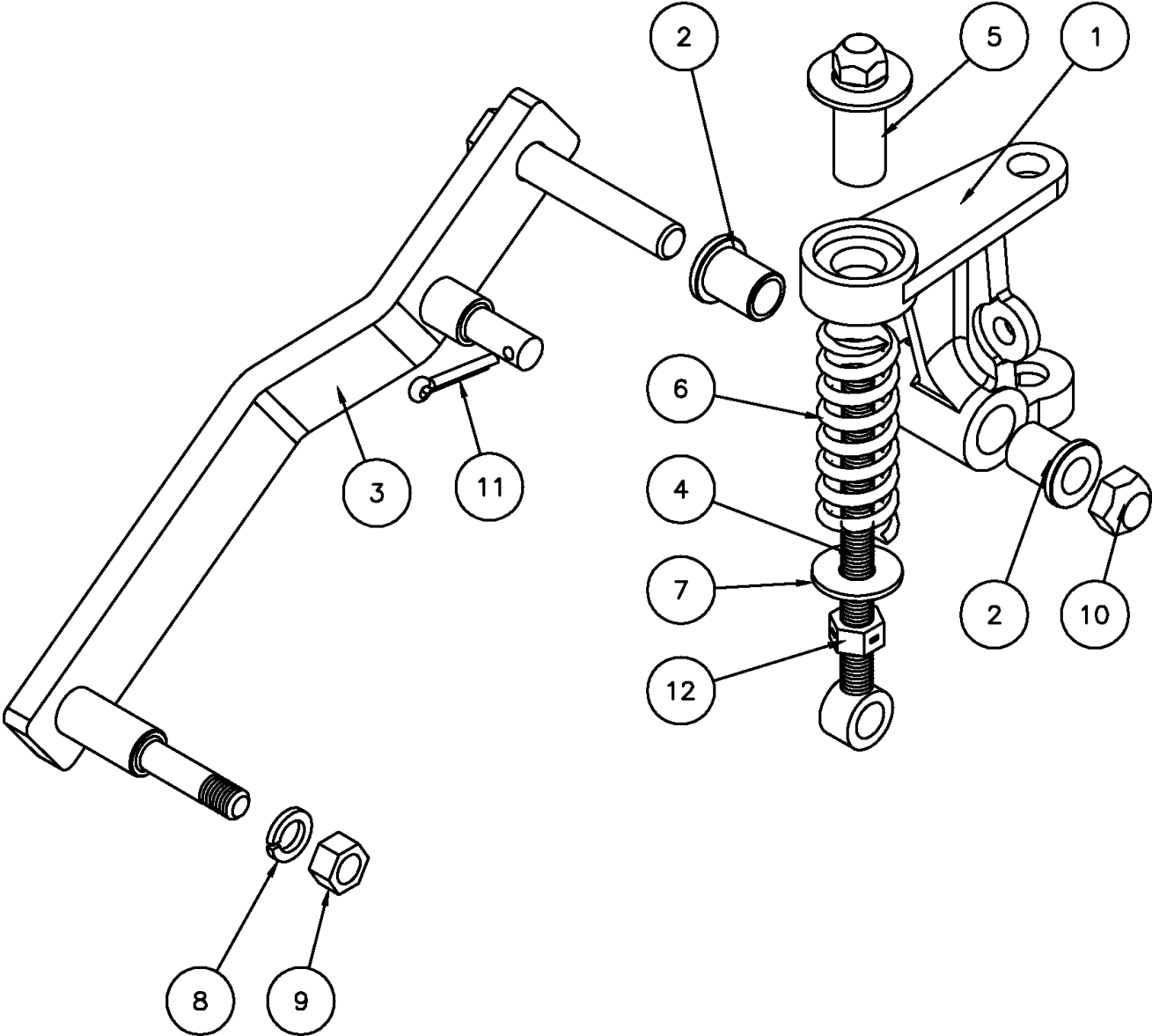



# Assembly and Parts

## Packer

Item	Part No	Rev	Description	Qty
1	316003	0	SWIVEL BRACKET	1
2	312098	2	BUSHING 3/4 ID	2
3	301107	5	PACKER LEG SINGLE	1
4	301105	1	SPRING ROD	1
5	301106	2	PACKER ADJ NUT	1
6	301059	5	SPRING	1
7	WF1028134P	0	WASHER USS 5/8 PL	1
8	WL10P	0	WASHER LOCK 5/8 PL	1
9	SN10C5P	0	NUT 5/8 UNC GR5 PL	1
10	LS12CBP	0	LOCKNUT STOVER 3/4 UNC GRB PL	1
11	213608	0	COTTER PIN 1/4 X 1 1/2	1
12	LR10CP	0	LOCKNUT RVR SBL 5/8 UNC PL	1

# Assembly and Parts

## Arm

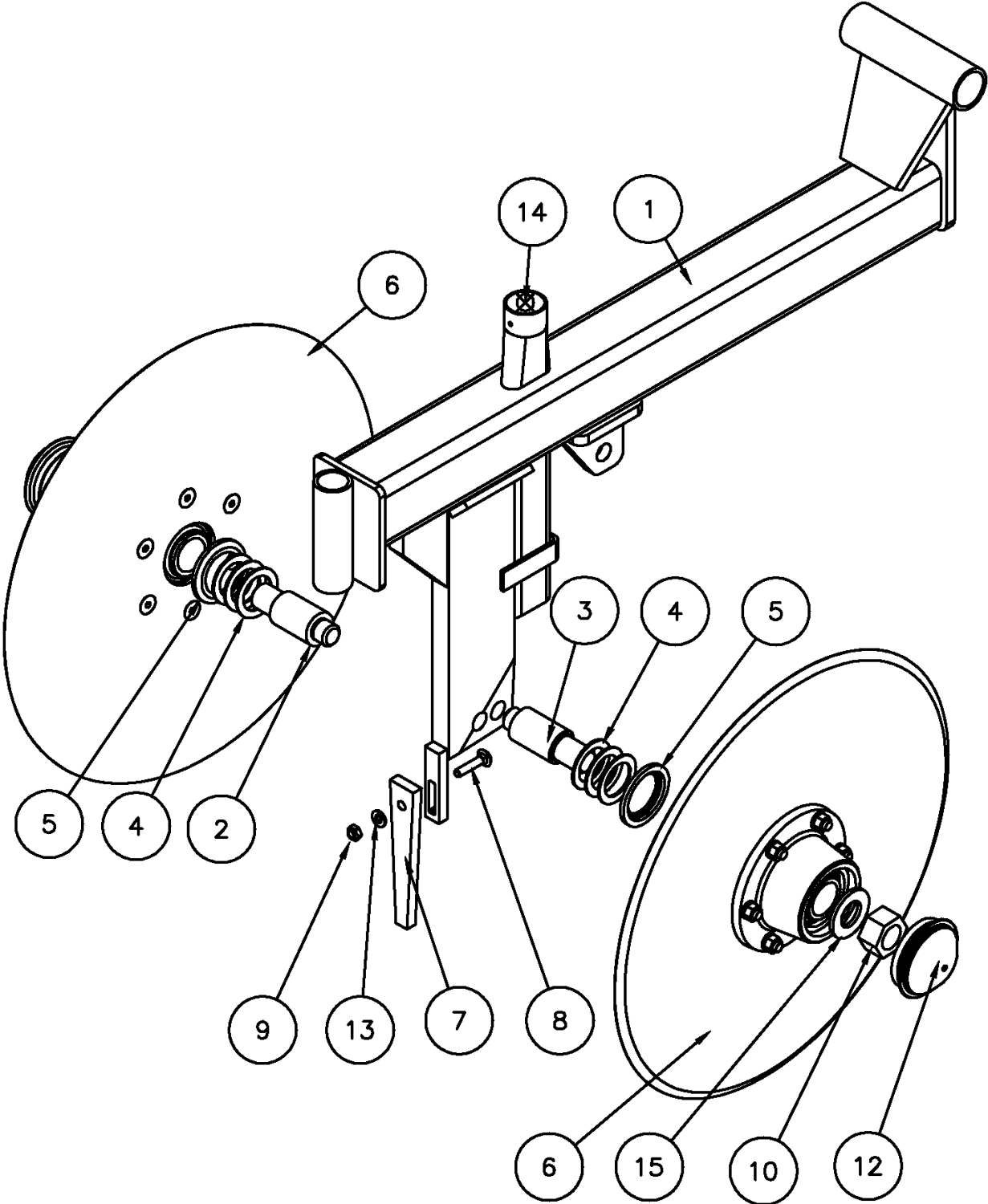

# Assembly and Parts

## Arm

Item	Part No	Rev	Description	Qty
1	312031	3	ARM WELDMENT	1
2	150712	3	SPINDLE, LEFT	1
3	150710	4	SPINDLE, RIGHT	1
4	150701	2	SPINDLE WASHER	6
5	301560	3	INNER SEAL	2
6	268015	0	DISC ASSEMBLY	2
7	312047	1	SEED DEFLECTOR	1
8	CB0405C5P	0	BOLT, CARRIAGE 1/4 X 1 1/4 UNC GR5 PL	1
9	LS04CCP	0	NUT, STOVER LOCK, 1/4 UNC GRC PL	1
10	SN14C5B	0	NUT, 7/8 UNC GR5 BL	1
11	SN14C5BLH	0	NUT, 7/8 UNC GR5 BL LH	1
12	301037	1	DUST CAP	2
13	WF0409065P	0	WASHER SAE 1/4 PL	1
14	312022	2	SEED TUBE	1
15	WF1428134P	0	WASHER SAE 7/8 PL	2

# Assembly and Parts

## Discs

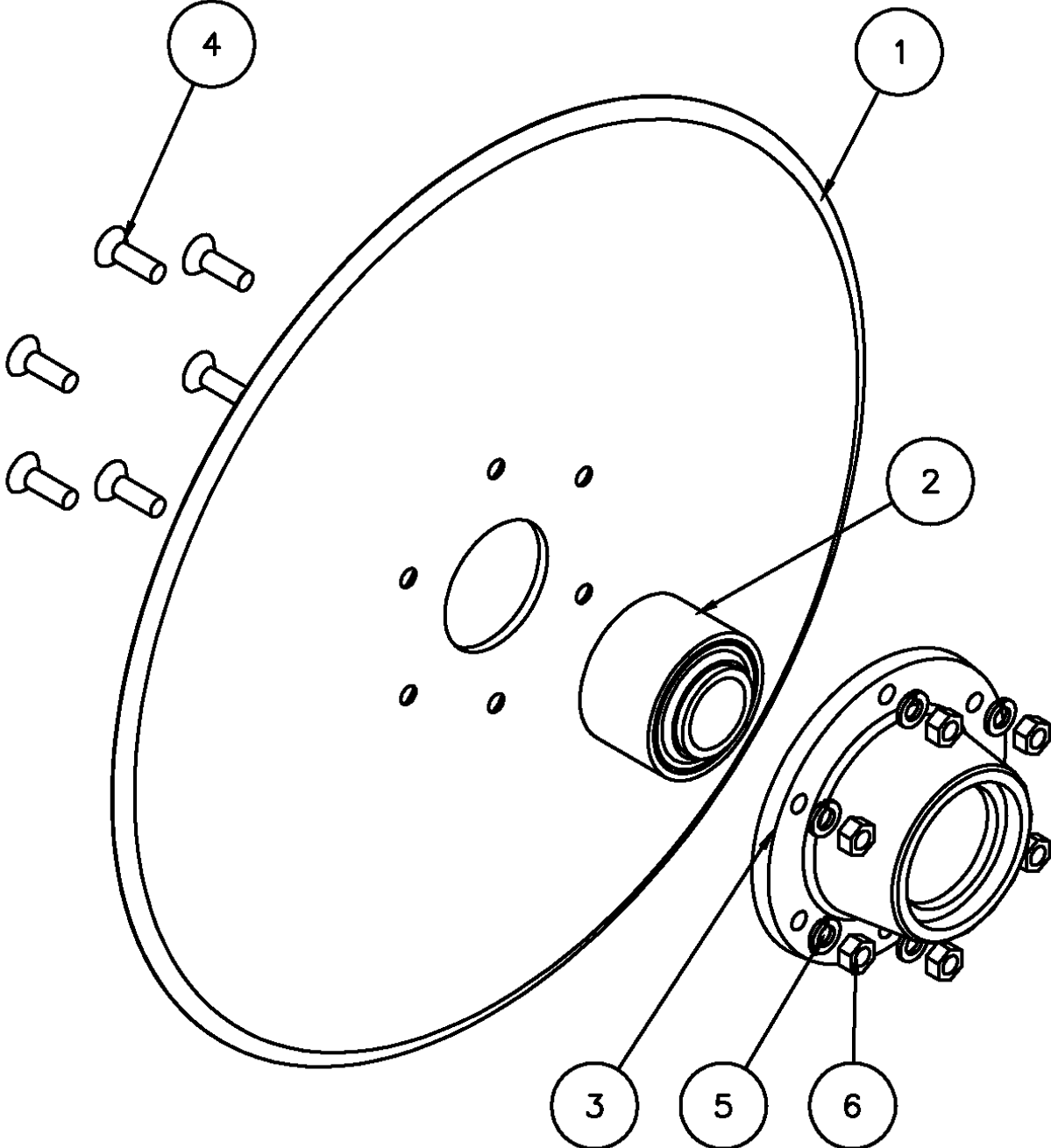

# Assembly and Parts

---

## Discs

Item	Part No	Rev	Description	Qty
1	370910 370912	1 0	BLADE 16" BLADE 17" (OPTIONAL)	1
2	370960	0	BEARING	1
3	370950	2	HUB	1
4	CSSF0504CP	0	ALLAN HEAD COUNTERSUNK CAP SCREW 5/16 X 1 PL	6
5	WL05P	0	LOCKWASHER 5/16 PL	6
6	SN05C5P	0	NUT 5/16 UNC GR5 PL	6

# Assembly and Parts

## Mounting

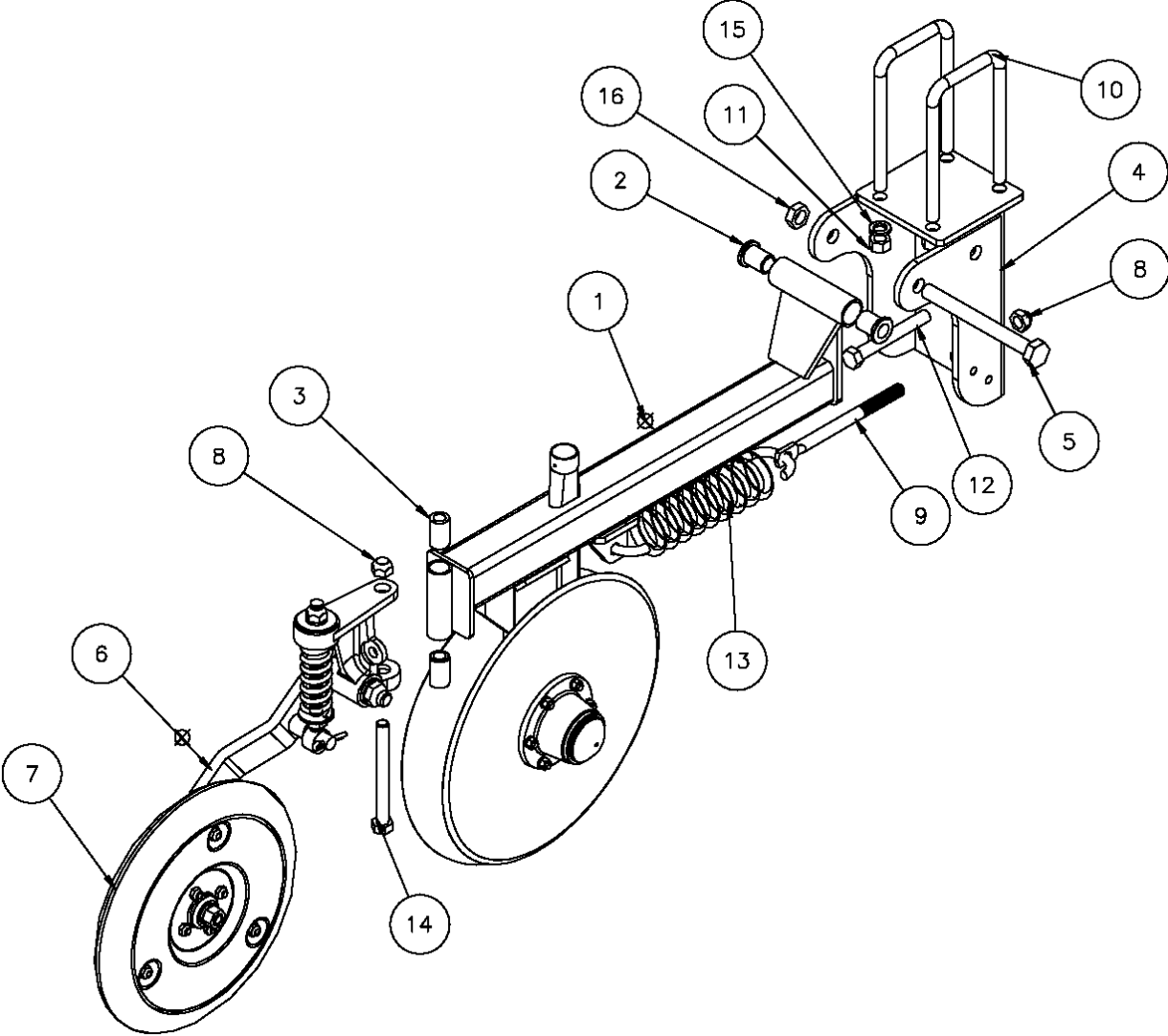

# Assembly and Parts

## Mounting



Item	Part No	Rev	Description	Qty
1	318040	0	ARM ASSEMBLY 3612	1
2	312098	3	BUSHING 3/4 ID	2
3	302013	0	BUSHING 5/8 ID	2
4	312046	0	MOUNT	1
5	T1230C325P	0	BOLT 3/4 X 7 1/2 UNC STRCTL PL	1
6	318015	0	PACKER ASSEMBLY 36	1
7	VARIES		SEE PG 25	1
8	LS10CBP	0	NUT, STOVER LOCK, 5/8 UNC GRB PL	2
9	312077 312076	1	SPRING BOLT 8" SPRING BOLT 4"	1
10	219614 219601	0	U-BOLT 5/8 X 4 X 7 1/2 U-BOLT 5/8 X 4 X 5 1/2	2 2
11	SN10C5P	0	NUT 5/8 UNC GR5 PL	4
12	SB1022C5P SB1006C5P	0	BOLT 5/8 X 5 1/2 UNC GR5 PL BOLT 5/8 X 1 1/2 UNC GR5 PL	1 1
13	140350 312085	4 0	SPRING HEAVY SPRING LIGHT (AUSTRALIA)	1 1
14	SB1024C5P	0	BOLT 5/8 X 6 UNC GR5 PL	1
15	WL10P	0	WASHER LOCK 5/8 PL	4
16	JN12C5P	0	NUT JAM 3/4 UNC GR5 PL	1

Spring tension bolts (item #9) and stop bolts (item #12) are selected based on position of assembly. For the forward position select the shorter items, for the rearward position select the longer items.

# Assembly and Parts

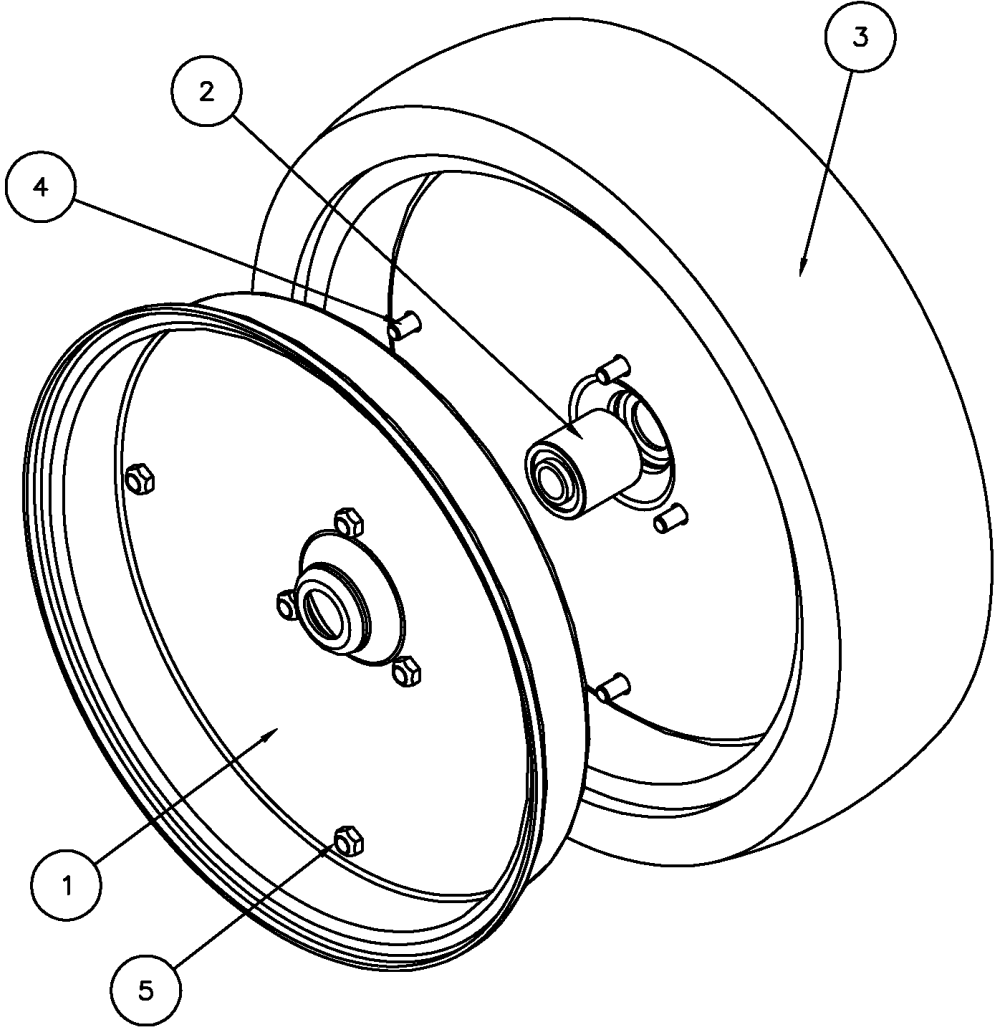
## Wheels

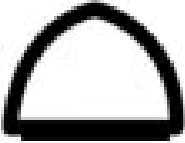

Flat Tread	V-Tread	Double Rib	Single Rib
			



# Assembly and Parts

## Wheels

Item	Part No	Rev	Description	Qty
1	326103	0	WHEEL HALF 2 X 16	2
	326104	0	WHEEL HALF 4 X 14	
	326105	0	WHEEL HALF 3 X 13	
	326106	0	WHEEL HALF 2 X 14	
	326107	0	WHEEL HALF 2 X 13	
	326108	0	WHEEL HALF 4 X 12	
2	326150	0	BEARING	1
3	RO216FT	0	TIRE 2 X 16 FLAT TREAD	1
	RO313FT	0	TIRE 3 X 13 FLAT TREAD	
	RO213FT	0	TIRE 2 X 13 FLAT TREAD	
	RO316VT	0	TIRE 3 X 16 V TREAD	
	RO414VT	0	TIRE 4 X 14 V TREAD	
	RO313VT	0	TIRE 3 X 13 V TREAD	
	RO214VT	0	TIRE 2 X 14 V TREAD	
	RO313DR	0	TIRE 3 X 13 DOUBLE RIB	
	RO313SR	0	TIRE 3 X 13 SINGLE RIB	
	RO213SR	0	TIRE 2 X 13 SINGLE RIB	
4	SB05025C5P	0	BOLT 5/16 X 5/8 UNC GR5 PL	7
5	LS05CCP	0	LOCK NUT 5/16 UNC PL	7
	WO216FT	0	WHEEL ASSEMBLY 2 X 16 FLAT TREAD (COMPLETE)	
	WO313FT	0	WHEEL ASSEMBLY 3 X 13 FLAT TREAD (COMPLETE)	
	WO213FT	0	WHEEL ASSEMBLY 2 X 13 FLAT TREAD (COMPLETE)	
	WO316VT	0	WHEEL ASSEMBLY 3 X 16 V TREAD (COMPLETE)	
	WO414VT	0	WHEEL ASSEMBLY 4 X 14 V TREAD (COMPLETE)	
	WO313VT	0	WHEEL ASSEMBLY 3 X 13 V TREAD (COMPLETE)	
	WO214VT	0	WHEEL ASSEMBLY 2 X 14 V TREAD (COMPLETE)	
	WO313DR	0	WHEEL ASSEMBLY 3 X 13 DOUBLE RIB (COMPLETE)	
	WO313SR	0	WHEEL ASSEMBLY 3 X 13 SINGLE RIB (COMPLETE)	
	WO213SR	0	WHEEL ASSEMBLY 2 X 13 SINGLE RIB (COMPLETE)	

# Assembly and Parts

## Mud Scraper

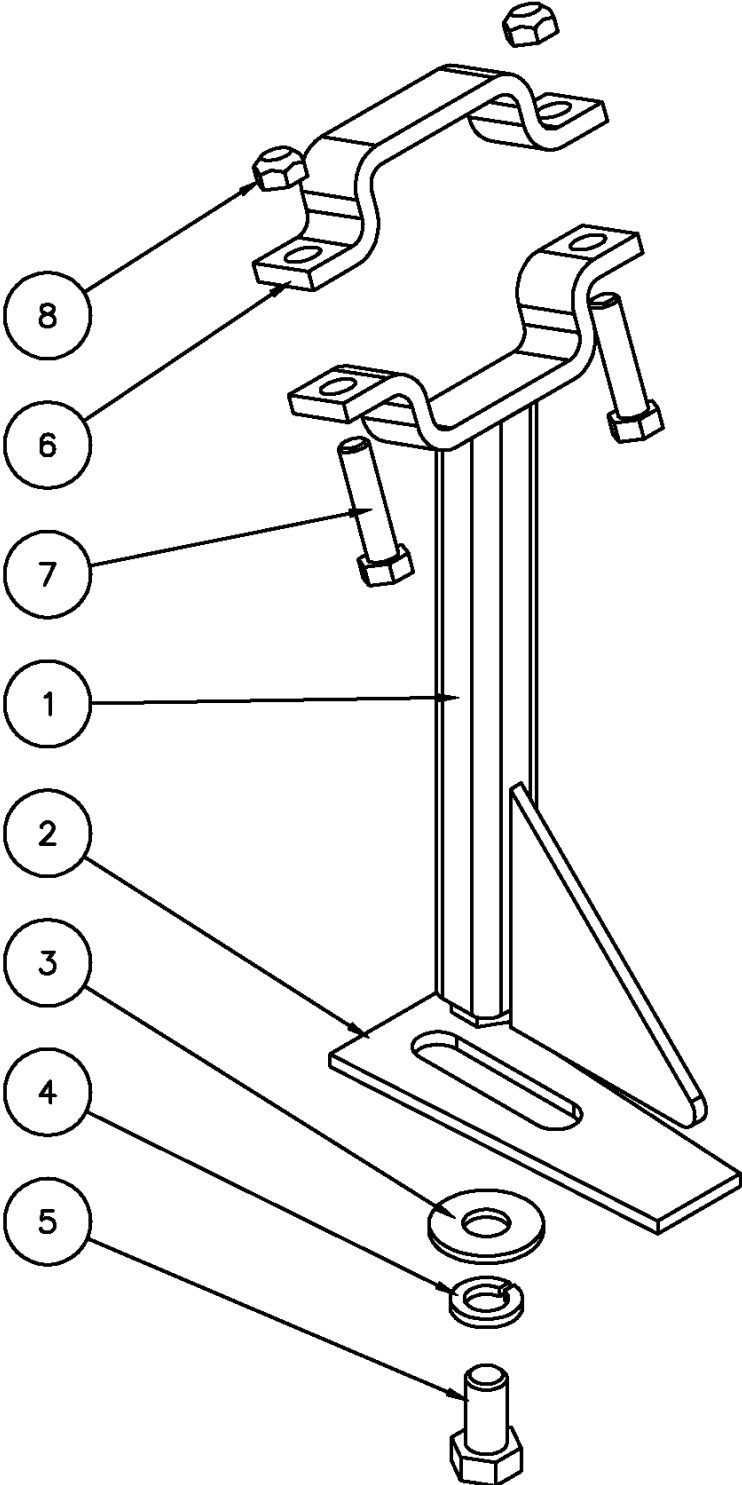

# Assembly and Parts

---

## Mud Scraper

Item	Part No	Rev	Description	Qty
1	2000540	1	MUD SCRAPER MNT	1
2	2000130	8	MUD SCRAPER PL	1
3	WF0822109P	0	WASHER, USS, 1/2 PL	1
4	WL08P	0	WASHER LOCK 1/2 PL	1
5	SB0804C5P	0	BOLT 1/2 X 1 UNC GR5 PL	1
6	2000330	1	CLAMP	1
7	SB0606C5P	0	BOLT 3/8 X 1 1/2 UNC GR5 PL	2
8	LS06CCP	0	NUT, STOVER LOCK, 3/8 UNC GRC PL	2

# Assembly and Parts

## Residue Manager

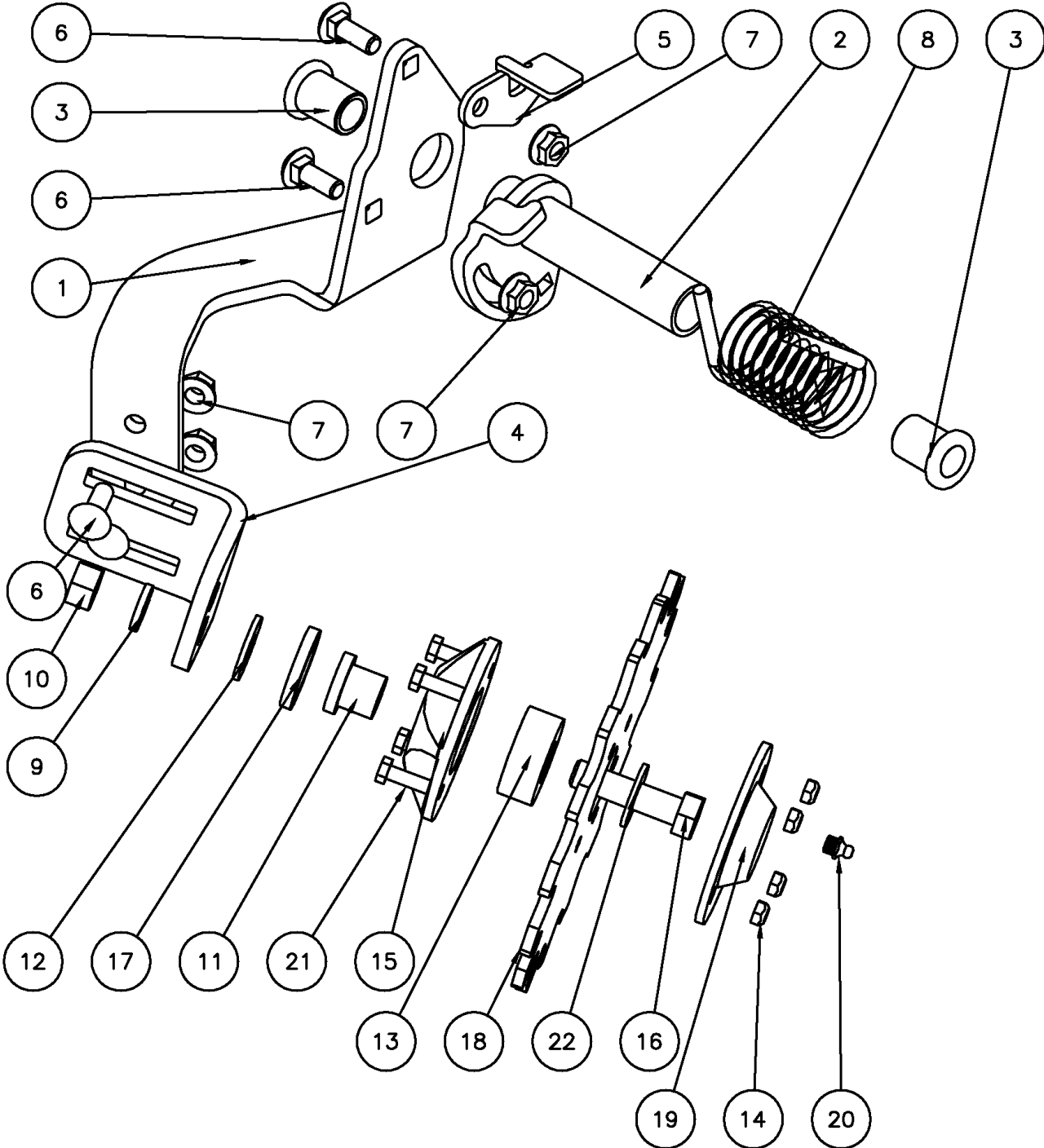

# Assembly and Parts

## Residue Manager

Item	Part No	Rev	Description	Qty
1	312163	2	ARM	1
2	312169	1	PIVOT	1
3	312098	2	BUSHING 3/4 ID	2
4	312181	3	TILT BRACKET	1
5	312183	0	LOCK UP TAB	1
6	CB0705C5P	0	BOLT CARRIAGE 7/16 X 1 1/4 UNC PL	4
7	LS07CGFP	0	NUT, STOVER FLANGE 7/16 UNC GRG PL	4
8	312192	0	SPRING	1
9	WL10P	0	WASHER LOCK 5/8 PL	1
10	SN10C5P	0	NUT 5/8 UNC GR5 PL	1
11	316126	0	INSERT	1
12	313004	0	DUST SEAL	1
13	316125	0	BEARING	1
14	LS05CCP	0	NUT STOVER LOCK 5/16 UNC GRC PL	4
15	316120	0	HUB	1
16	SB1010C5P	0	BOLT 5/8 X 2 1/2 UNC GR5 PL	1
17	CR13548	0	SEAL	1
18	370211	2	WHEEL	1
19	316121	0	HUB CAP	1
20	91700	0	GREASE NIPPLE	1
21	SB0504C5P	0	BOLT 5/16 X 1 UNC GR5 PL	4
22	WF0923109P	0	WASHER FLAT 9/16 USS PL	1

# Assembly and Parts

## Residue Manager

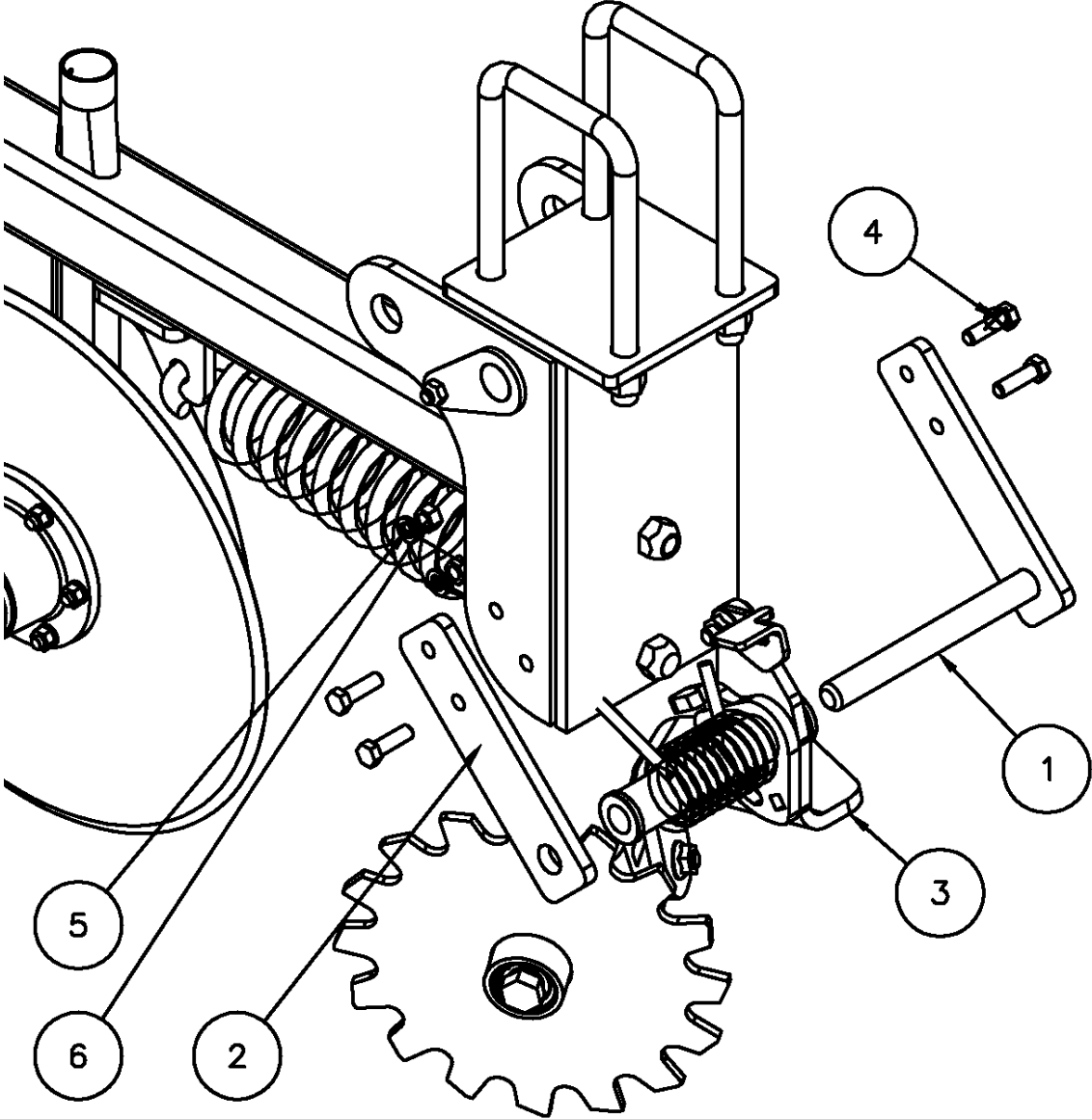

## Residue Manager

Item	Part No	Rev	Description	Qty
1	312168	1	MOUNT BRACKET	1
2	312150	1	MOUNT PL	1
3	318060	0	RESIDUE MANAGER ASSEMBLY	1
4	SB0605C5P	0	BOLT 3/8 X 1 1/4 UNC GR5 PL	4
5	WL06P	0	WASHER LOCK 3/8 PL	4
6	SN06C5P	0	NUT 3/8 UNC GR5 PL	4

On earlier models, holes will have to be drilled in the mount cap to accommodate the residue manager. See the drawing below.

